

User's Guide

Agilent Technologies E4406A VSA Series Transmitter Tester



Agilent Technologies

Manufacturing Part Number: E4406-90130

Printed in USA

February 2000

© Copyright 1999 - 2000 Agilent Technologies, Inc.

The information contained in this document is subject to change without notice.

Agilent Technologies makes no warranty of any kind with regard to this material, including but not limited to, the implied warranties of merchantability and fitness for a particular purpose. Agilent Technologies shall not be liable for errors contained herein or for incidental or consequential damages in connection with the furnishing, performance, or use of this material.

Safety Information

The following safety notes are used throughout this manual. Familiarize yourself with these notes before operating this instrument.

WARNING	Warning denotes a hazard. It calls attention to a procedure which, if not correctly performed or adhered to, could result in injury or loss of life. Do not proceed beyond a warning note until the indicated conditions are fully understood and met.
---------	---

CAUTION	Caution denotes a hazard. It calls attention to a procedure that, if not correctly performed or adhered to, could result in damage to or destruction of the instrument. Do not proceed beyond a caution sign until the indicated conditions are fully understood and met.
---------	---

WARNING	This is a Safety Class 1 Product (provided with a protective earth ground incorporated in the power cord). The mains plug shall be inserted only in a socket outlet provided with a protected earth contact. Any interruption of the protective conductor inside or outside of the product is likely to make the product dangerous. Intentional interruption is prohibited.
---------	--

WARNING	No operator serviceable parts inside. Refer servicing to qualified personnel. To prevent electrical shock do not remove covers.
---------	--

CAUTION	Always use the three-prong AC power cord supplied with this product. Failure to ensure adequate grounding may cause product damage.
---------	---

Warranty

This Agilent Technologies instrument product is warranted against defects in material and workmanship for a period of three years from date of shipment. During the warranty period, Agilent Technologies will, at its option, either repair or replace products that prove to be defective.

For warranty service or repair, this product must be returned to a service facility designated by Agilent Technologies. Buyer shall prepay shipping charges to Agilent Technologies and Agilent Technologies shall pay shipping charges to return the product to Buyer. However, Buyer shall pay all shipping charges, duties, and taxes for products returned to Agilent Technologies from another country.

Agilent Technologies warrants that its software and firmware designated by Agilent Technologies for use with an instrument will execute its programming instructions when properly installed on that instrument. Agilent Technologies does not warrant that the operation of the instrument, or software, or firmware will be uninterrupted or error-free.

LIMITATION OF WARRANTY

The foregoing warranty shall not apply to defects resulting from improper or inadequate maintenance by Buyer, Buyer-supplied software or interfacing, unauthorized modification or misuse, operation outside of the environmental specifications for the product, or improper site preparation or maintenance.

NO OTHER WARRANTY IS EXPRESSED OR IMPLIED. AGILENT TECHNOLOGIES SPECIFICALLY DISCLAIMS THE IMPLIED WARRANTIES OF MERCHANTABILITY AND FITNESS FOR A PARTICULAR PURPOSE.

EXCLUSIVE REMEDIES

THE REMEDIES PROVIDED HEREIN ARE BUYER'S SOLE AND EXCLUSIVE REMEDIES. AGILENT TECHNOLOGIES SHALL NOT BE LIABLE FOR ANY DIRECT, INDIRECT, SPECIAL, INCIDENTAL, OR CONSEQUENTIAL DAMAGES, WHETHER BASED ON CONTRACT, TORT, OR ANY OTHER LEGAL THEORY.

Contents

1. Getting Started	
What Comes with the E4406A VSA Series Transmitter Tester	17
URL for the Latest VSA Transmitter Tester Update	19
Understanding Digital Communications Measurements	19
Updating the Firmware	19
How to Make a Measurement	20
Front Panel Key Maps of Context Dependency	21
Front Panel Description	25
Rear Panel Description	32
Display Annotation	35
Installing Optional	
Measurement Personalities	38
Available Personality Options	39
License Key Numbers	39
Installing a License Key Number	40
Using the Uninstall Key	41
Cables for Connecting to the Serial Port	
(RS-232)	42
Safety Considerations	48
Instrument Installation	48
Instrument Operation and Maintenance	49
2. Using System Features	
Using System Keys	52
Install and Uninstall	52
Key Locations	53
Using I/O, Front and Rear Panel Keys	62
Configuring I/O	62
Reference	64
Using Alignment & Configuration Keys	65
Alignment	65
Restore Sys Defaults	69
Show Errors	69
Show System	70
System (Local)	70
Using File and Save Keys	71
Loading a State	71
Saving a State	71
Using the Alpha Editor Menu	72
Using Printers	73
Selecting a Type of Printer	73
How to Print	73
How to Save a Screen Image to a Floppy Disc	73
3. Setting the Mode	
Selecting a Mode	76
Mode Setup	77
Input Keys	77

Contents

Trigger Keys	79
Selecting the Frequency/Channel	80
4. Making Measurements	
Basic Measurements	82
Preparing for Measurements	83
Initial Setup	83
Using Measure Keys	83
Measurement Control	84
Measurement Setup	84
Changing the View	87
Using Markers	89
Making the Spectrum (Frequency Domain) Measurement	91
Purpose	91
Measurement Method	91
Making the Measurement	91
Results	91
Changing the Measurement Setup	93
Changing the View	97
Using the Markers	97
Troubleshooting Hints	98
Making the Waveform (Time Domain) Measurement	99
Purpose	99
Measurement Method	99
Making the Measurement	99
Results	100
Changing the Measurement Setup	101
Changing the View	104
Using the Markers	104
Troubleshooting Hints	105
Making the Channel Power Measurement	106
Purpose	106
Measurement Method	106
Making the Measurement	106
Results	107
Changing the Measurement Setup	108
Changing the Display	109
Troubleshooting Hints	110
Making the Adjacent Channel Power (ACP) Measurement	111
Purpose	111
Measurement Method	111
Making the Measurement	112
Results	112
Changing the Measurement Setup	114
Changing the View	118
Troubleshooting Hints	119
Service Measurements	120
Making the Power vs. Time Measurement	121
Purpose	121

Contents

Measurement Method.....	121
Making the Measurement	121
Results	122
Changing the Measurement Setup	123
Changing the View	124
Timebase Frequency	125
Purpose	125
Measurement Method.....	125
Test Setup	125
Results	126
50 MHz Amplitude	127
Purpose	127
Measurement Method.....	127
Test Setup	127
Results	128
Sensors	129
Purpose	129
Measurement Method.....	129
Test Setup	129
Results	130
Front Panel Test	131
Purpose	131
Test Setup	131
Results	132
Troubleshooting Hints	132
5. Functional Testing	
What You'll Find in This Chapter	134
What Are the Functional Tests?.....	134
Functional Test Versus Performance Verification.....	134
Getting Started	135
Before You Start	135
Test Equipment	135
Equipment Connections	135
Test Descriptions	137
Frequency Response (Flatness)	138
Test Limits.....	138
Test Description	138
Required Equipment.....	138
Procedure.....	139
Amplitude Accuracy at 50 MHz.....	143
Test Limits.....	143
Test Description	143
Required Equipment.....	143
Procedure.....	144
Input Attenuator Accuracy at 50 MHz	148
Test Limits	148
Test Description	148
Required Equipment.....	148

Contents

Procedure	148
Displayed Average Noise Level (DANL).....	151
Test Limits	151
Test Description	151
Required Equipment	151
Procedure	152
Phase Noise	154
Test Limits	154
Test Description	154
Required Equipment	155
Procedure	155
Residual Responses	160
Test Limits	160
Test Description	160
Required Equipment	160
Procedure	160

6. If You Have a Problem

Problem Symptoms and Solutions	166
Key or Feature Does Not Appear in Menu	166
Frequency Unlock or External Reference Missing - Error Messages	167
LAN External Loopback Test Failed - Error Message	167
Instrument Fails Alignment - Error Message	167
Measurement Keys Do Not Appear after Pressing the Mode Key	168
Instrument Power-On Problem	168
LAN Communication Problem.....	168
Error Queues	169
Front Panel Error Messages	169
SCPI Remote Interface Error Messages	172
Clearing the Error Queue	173
No Error	173
Error Message Descriptions	174
Messages with No Numbers	174
Query Error Messages	
[-499 to -400]	175
Device-Specific Error Messages	
[-399 to -300]	177
Execution Error Messages	
[-299 to -200]	179
Command Error Messages	
[-199 to -100]	186
Instrument-Specific Error Messages	
[positive numbers]	191
Core-Specific Error Messages	
[1 to 99]	191
GSM-Specific Error Messages	
[100 to 199]	195
CDMA-Specific Error Messages	
[200 to 299]	197

Contents

NADC-Specific Error Messages [300 to 399]	198
PDC-Specific Error Messages [400 to 499]	199
Warranty Information	200
Returning Your Instrument to Agilent Technologies	201
Blue Repair Tag goes here	203

7. Options and Accessories

Options and Measurement Personalities	206
Option BAH	206
Option BAC	206
Option BAE	206
Option HN1	206
Option BAF	206
Option B78	206
Option 300	206
Option 0B1	207
Option 0BV	207
Option 0BW	207
Option 1CM	207
Option 1CN	207
Option 1CP	207
Option 1CR	207
VSA Transmitter Tester Measurement Personalities Retrofit	208
Accessories	209
AC Probe	209
Broadband Preamplifiers and Power Amplifiers	209
GPIB Cable	209
Parallel Interface Cable	209
Printer	209
RS-232 Cables	210
N2714A Calibration and Adjustment Software	210
Support Documentation	211

List of Key Descriptions

10 MHz Out.....	64
50 MHz Amplitude.....	127
50 MHz Amptd.....	127
50 MHz Ref.....	77
Abs Limit.....	116
Absolute.....	116
ADC Dither	103
ADC Range.....	95
Adjacent Channel Power	112
Advanced	84
Align 50 MHz Reference.....	66
Align ADC	66
Align All Now.....	66
Align Current IF Flatness.....	67
Align Current SysGain.....	67
Align IF.....	66
Align RF	66
Align Subsystem	66
Alignments	65
Alpha Editor.....	72
Auto Align	66
Auto Peak	95
Auto Trig	79
Auto	95
AutoPeakLock	96
Average.....	85
Avg Bursts.....	85
Avg Mode.....	85
Avg Number	85
Avg Type.....	86
Band Power	90
Bar Graph.....	118
Basic	76
Blackman Harris.....	95
Blackman.....	95
Burst.....	124
cdmaOne.....	76
Chan Pwr Span	108
Channel Power.....	106
Clear Error Queue(s)	69
Config I/O	62
Corrections	67
Current	87
Data Packing.....	96
Data Points.....	109
Decimation	103
Delay.....	79
Delta	90
Diagnostics	70

List of Key Descriptions

Emulated GPIB Address.....	63
Emulated GPIB Logical Unit	63
Emulated GPIB Name	63
ESC	65
Ethernet Addr	63
Exit Main Firmware	38
Ext Atten	110
Ext Front	80
Ext Rear.....	80
Fail	116
FFT Length	95
FFT Size	95
FFT Window.....	95
File Location.....	73
File System.....	63
File Type.....	73
Flat Top.....	95
Frame Timer.....	80
Frame.....	86
Free Run	86
Freq Ref	64
Front Panel Test.....	131
Function.....	105
Gaussian.....	95
GPIB Address.....	62
GSM.....	76
Hamming.....	95
Hanning.....	95
Host Name.....	63
I only	77
I/Q Input Z.....	78
I/Q	77
IF Align.....	77
Input Atten.....	78
Input Port	77
Install.....	38
Instrument Logical Unit.....	63
Instrument Name.....	63
Integ BW.....	108
IP Address	62
K-B 70dB / 90dB/ 110dB (Kaiser-Bessel)	95
Length Ctrl.....	95
Level.....	79
License Key	39
License Key	40
Limit Setup.....	116
Line	86
Load State	71
Log-Pwr Avg.....	86

List of Key Descriptions

Long (32 bit)	103
Manual	96
Marker All Off.....	90
Max Total Pwr.....	78
Maximum Connections.....	63
Maximum	86
Meas Time.....	123
Meas Type	117
Medium (24 bit).....	103
Min Pts in RBW.....	95
Minimum.....	86
Noise.....	90
Normal.....	89
Num FFT Seg.....	117
Offset Adv.....	117
Offset Freq.....	116
Offset Side.....	116
Offset	116
Offset	80
Peak Level.....	79
Period.....	80
Pos.....	79
Pre-ADC BPF.....	94
Pre-FFT BW.....	94
Pre-FFT Fltr.....	94
Print To.....	73
PSD Ref	117
Pwr Avg	86
Pwr vs Time	121
RBW Filter	123
Ref Position	88
Ref Value	88
Reference	64
Rel Lim (Car).....	117
Rel Lim (PSD)	117
Relative Att	117
Relative.....	117
Res BW	84
Reset Offset	80
Restore Align Defaults.....	67
Restore Meas Defaults.....	84
Restore Sys Defaults.....	69
Resume	84
RF Burst (Wideband).....	79
RF	77
Rise & Fall.....	124
Save State.....	71
Scale/Coupling.....	88
Scale/Div.....	88

List of Key Descriptions

SCPI Lan	63
Select.....	90
Sensors.....	129
Server.....	63
Service	76
Shape	90
Short (16 bit)	103
Show Errors.....	69
Show System	70
SICL Server.....	63
Signal Amptd.....	78
Signal Rate	78
Signal Type.....	78
Slope.....	79
Socket Port.....	63
Span	88
Spectrum (Freq Domain)	91
Spectrum	118
Sweep Time	88
Sync Source	80
Telnet Port	63
Time Corr	67
Timebase Frequency	125
Total Pwr Ref.....	117
Trace	89
Trig Holdoff	79
Trigger	79
Uniform.....	95
Uninstall.....	41
Video (IF Envlp)	79
Visible Align	68
Voltage Avg.....	86
Waveform (Time Domain).....	99
Window Length	95

1 **Getting Started**

This chapter introduces you to basic features of the instrument, including the front panel keys, rear panel connections, and display annotation. You will also find processes for making a basic measurement and for installing applications.

Topics include:

“What Comes with the E4406A VSA Series Transmitter Tester” on page 17

“How to Make a Measurement” on page 20

“Front Panel Key Maps of Context Dependency” on page 21

“Front Panel Description” on page 25

“Rear Panel Description” on page 32

“Display Annotation” on page 35

“Installing Optional Measurement Personalities” on page 38

“Safety Considerations” on page 48

“Cables for Connecting to the Serial Port (RS-232)” on page 42

What Comes with the E4406A VSA Series Transmitter Tester

With your purchase of the instrument you receive the following materials:

Table 1-1 Standard Documentation

Part Description	Notes
User's Guide	Includes E4406-90057 and E4406-90085
Specifications	Includes specifications for most optional measurement personalities. Special handling options may be documented elsewhere.
Programmer's Guide	Does not include commands for the optional measurement personalities
Documentation and Instrument Driver CD-ROM	Includes programming examples, does not include service documentation or software

An E4406A standard instrument contains the Basic and Service modes. If you have purchased an optional measurement personality, your instrument comes loaded with the personality you have selected plus the Basic and Service modes. You also receive the related measurement and programming guides for the options you have ordered.

Table 1-2 Personality Documentation

Measurement Option	Part Description
Option BAC	cdmaOne Measurement Guide
	cdmaOne Programming Commands
Option BAH	GSM Measurement Guide
	GSM Programming Commands
Option BAE	NADC, PDC Measurement Guide
	NADC, PDC Programming Commands
Option HN!	iDEN Measurement Guide (includes programming commands)
Option BAF	W-CDMA Measurement Guide
	W-CDMA Programming Commands
Option B78	cdma2000 Measurement Guide
	cdma2000 Programming Commands

Service documentation is available from Agilent Technologies.

NOTE

If the shipping container is damaged, or any part is missing, notify Agilent Technologies (see [page 201](#) for locations). When transporting the instrument use the original packaging or comparable packaging.

URL for the Latest VSA Transmitter Tester Update

For the latest information about this instrument, including firmware upgrades, application information, and product information, please visit the following URL: www.agilent.com/find/vsa/.

Understanding Digital Communications Measurements

Additional measurement application information is available through your local Agilent Technologies sales and service office. See the “If You Have a Problem” chapter for office location information. Some available application notes are listed below.

Description	Agilent Part Number
Digital Modulation in Communications Systems - An Introduction Application Note 1298	5965-7160E
Understanding CDMA Measurements for Base Stations and Their Components Application Note 1311	5968-0953E
Understanding GSM Transmitter Measurements for Base Transceiver Stations and Mobile Stations Application Note 1312	5966-2833E

Updating the Firmware

Updated versions of the E4406A VSA Transmitter Tester firmware will be available via several sources. Information on the latest firmware revision can be accessed through the following URL.

URL to Contact to Obtain Firmware Update Information
www.agilent.com/find/vsa/

How to Make a Measurement

The Making Measurements chapter is organized to help you follow the three-step process shown in the table below.

Step	Primary Key	Setup Keys	Related Keys
1. Select & setup a mode	Mode	Mode Setup, Input, Frequency Channel	System
2. Select & setup a measurement	Measure	Meas Setup	Meas Control, Restart
3. Select & setup view	View/Trace	Span X Scale, Amplitude Y Scale, Display, Next Window, Zoom	File, Save, Print, Print Setup, Marker, Search

The VSA E4406A transmitter tester enables you to make a wide variety of digital measurements, both through its native spectrum and waveform measurement capabilities, and through the measurement personality option(s) you have purchased to activate applications specific measurements that are based upon industry standards.

Front Panel Key Maps of Context Dependency

Many of the instrument features are context dependent. The functions that are available will change based on your selections of mode, mode setup, measurement, and measurement setup. The following figures represent the dependency relationships of the front panel keys.

Figure 1-1 System and Navigation Keys are not Context Dependent

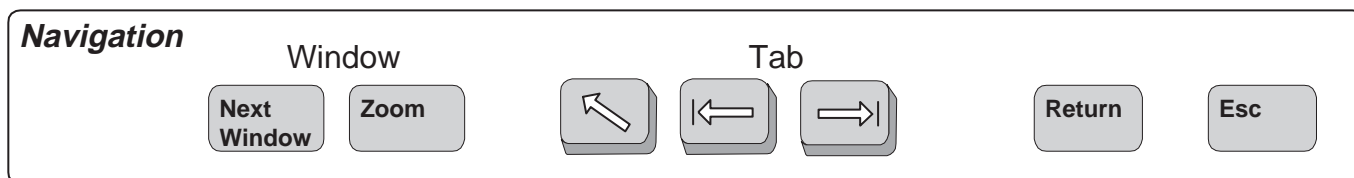
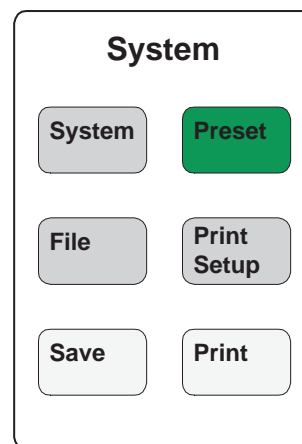
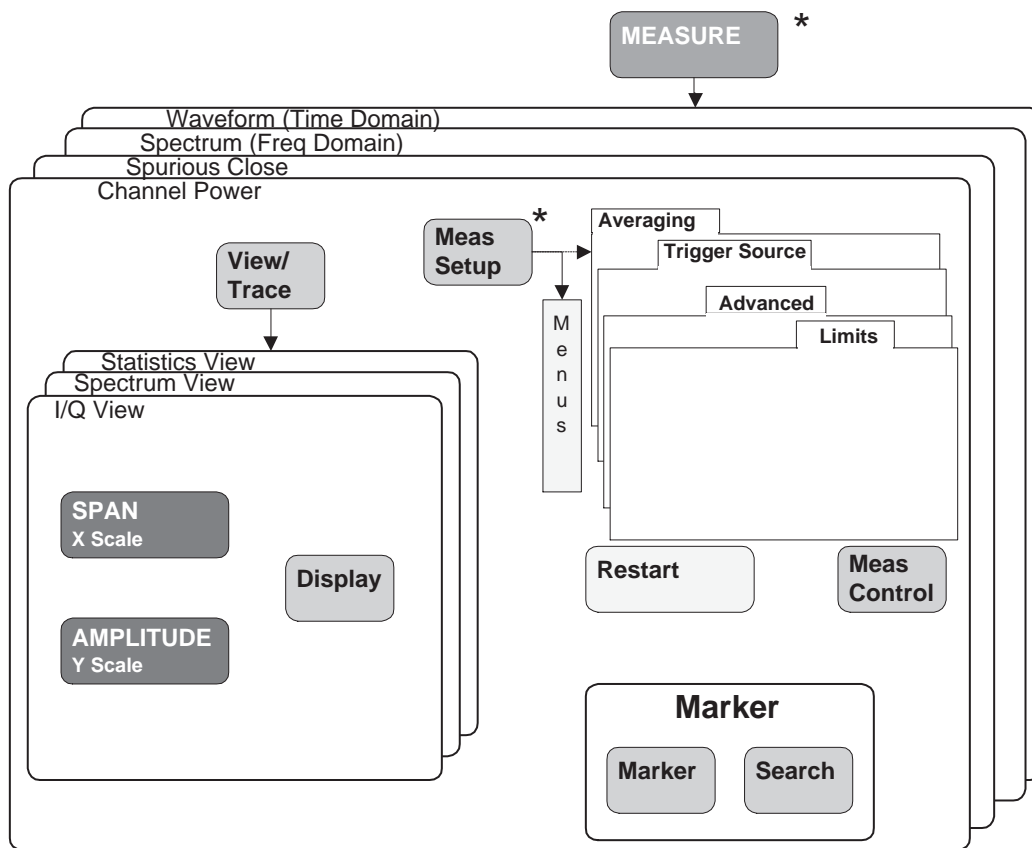
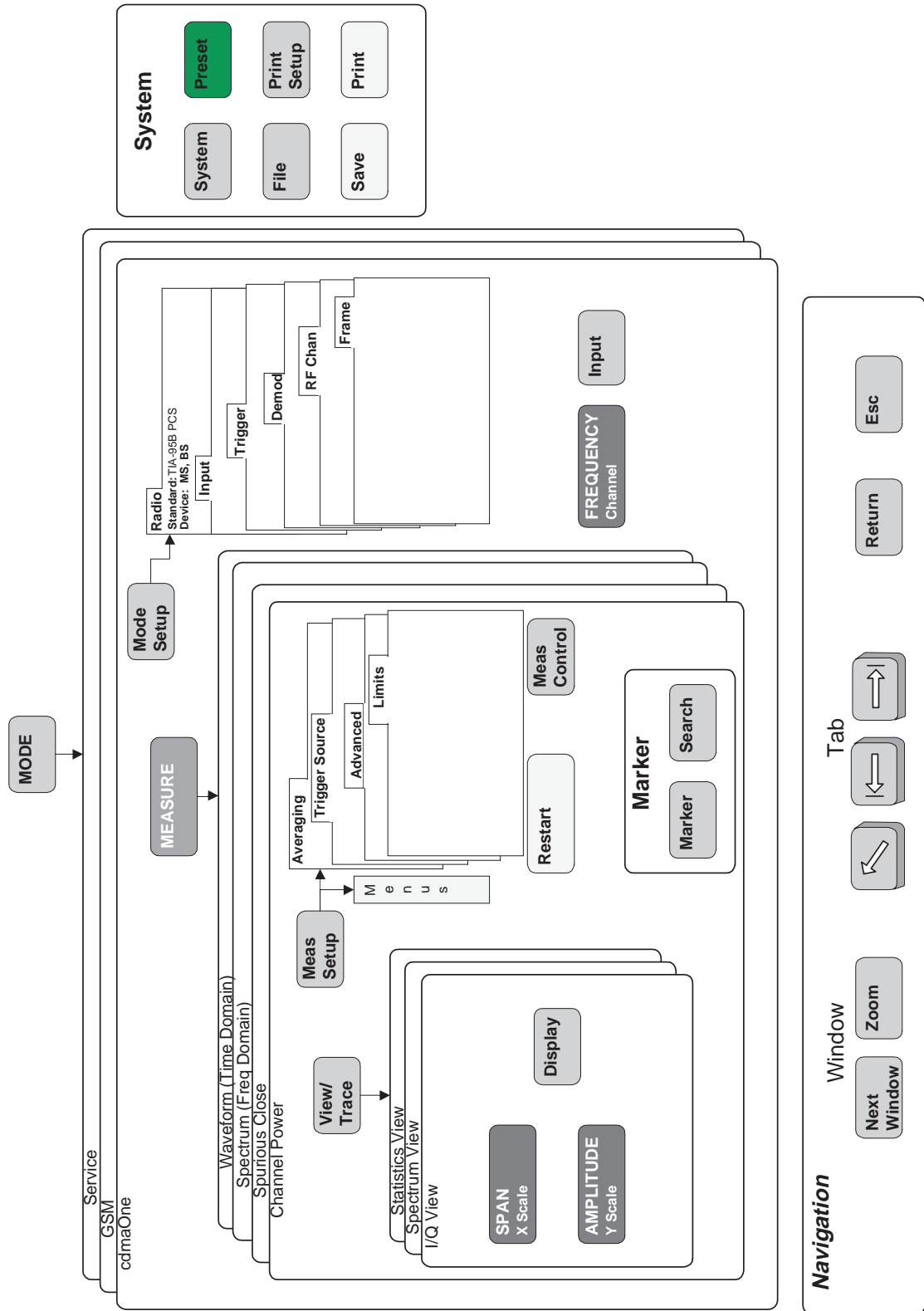

Figure 1-3 Context Dependent on the Selected Measure and Meas Setup



* Some **Measure** and **Meas Setup** parameters are context dependent upon the Radio variant and Device selected in the **Mode Setup**

Figure 1-4 Front Panel Keys Context Dependent Relationships



Front Panel Description

The hardkeys, softkeys and menus, RPG knob and step keys, and front panel inputs are explained below.

Softkeys either activate a feature or access a further softkey menu. There are seven softkeys. The softkey which is currently active is highlighted. Softkeys which are not available for use are greyed-out.

The transmitter tester uses five types of softkey:

- **Menu softkeys.** An arrow on the right side of a key label indicates that the key accesses a further menu.
- **Toggle softkeys.** A toggle softkey allows you to select between one of several settings (usually two settings, but there may be more) that are shown on a softkey; the available settings are listed underneath the softkey label, and the currently active setting is underlined. Pressing the toggle softkey will result in activating a setting that is adjacent to the initial, underlined setting.
- **Numeric softkeys.** A numeric softkey allows you to modify a numerical value. Current values are shown in the active function area of the display.
- **Numeric + Toggle softkeys.** A numeric + toggle softkey allows you, first, to toggle between an automatic or manual mode, and then, if you have selected manual, allows you to enter a numeric value.
- **Immediate action softkeys.** An immediate action softkey activates a feature immediately upon being pressed.

Softkey menus are dependent on the measurement chosen or the front panel key that has been activated. Many softkey menus contain more than seven softkeys, and cannot be displayed on a single-page menu. Multiple page menus are accessed by pressing a **More** key, which will be the bottom key of the menu.

Paths to access any feature will be found in the key access table on [page 53](#). Display annotation is explained on [page 35](#). Operation of the 3.5 inch floppy-drive is covered in the section on printing on [page 73](#).

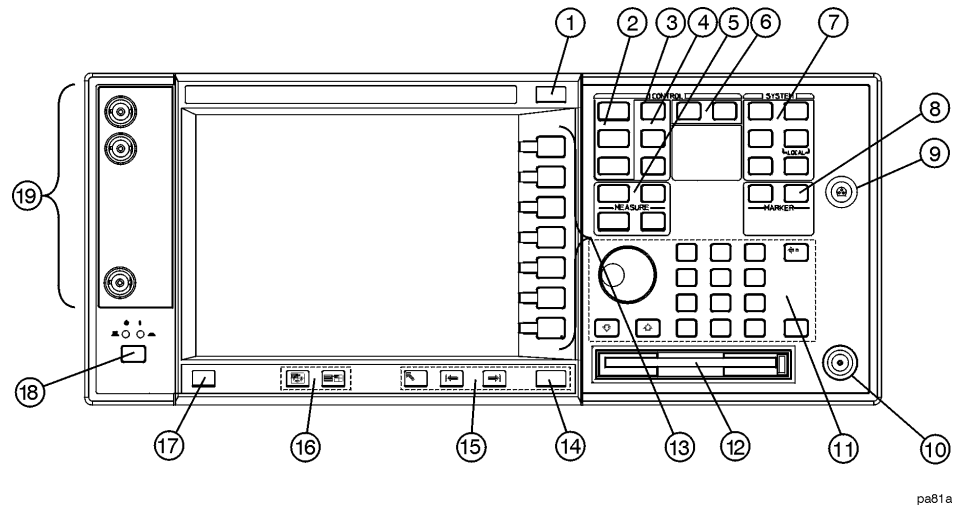

- 1. ESC key** Use the escape key to exit any function without modifying current parameters. Pressing the **ESC** key will:
- Clear any numeric entry that you have begun to enter but decided you want to cancel.
 - Remove any entries that are visible in the active function area of the display (see the section on annotation on [page 35](#) for a description of the active function area and other display features).
 - Cancels a print, if one is in progress.
 - Cancels an alignment, if one is in progress.
- 2. Control keys** set parameters that are used by the measurement in the current measurement mode.
- *FREQUENCY/Channel* accesses softkeys that control the center frequency or channel number. These parameters apply to all measurements in the current mode.
 - *SPAN/X Scale* accesses softkeys that control the horizontal scale in units of frequency, time, symbols or bits. The parameters in this menu apply only to the active window in the current measurement. See [page 87](#) for more detail.

- *AMPLITUDE/Y Scale* accesses softkeys that control vertical scale functions in units of dBm, dB, volts, degrees, or radians. The parameters in this menu apply only to the active window in the current measurement. See [page 87](#) for more detail.

3. Input key The **Input** key accesses softkeys that control the input of the transmitter tester. These affect all measurements within the current mode. Note that the internal 50 MHz reference signal and the IF align signal are used as internal inputs that do not require external connections. See [page 65](#) for more detail.

4. View keys **View** keys modify the format of the trace and numeric data on the display. See [page 87](#) for more detail.

- **View/Trace** accesses softkeys that control the way results are viewed.
- **Display** accesses softkeys that change the display. Functions such as limit mask on/off and dots on/off are available for some measurements.

5. Measure keys are used to select and set up a specific measurement within the selected application. See [page 83](#) for more detail.

- **MEASURE** accesses softkeys that select and initiate the various measurements that are specific to the current mode.
- **Meas Setup** accesses the setup parameters that are specific to the current measurement.
- **Restart** causes the measurement that is currently in process to stop, then start again at the beginning according to the current measurement setup parameters.
- **Meas Control** accesses softkeys that affect the measurement after it has been setup, for example selecting a single or continuous measurement.

6. Mode keys select the measurement mode and mode parameters such as input and trigger settings. See [page 77](#) for more detail.

- **MODE** accesses softkeys to select the instrument mode. Each mode is independent of all other modes.
- **Mode Setup** accesses softkeys that affect parameters that are specific to the current mode and affect all measurements within that mode.

7. System keys access system features, that are used with all instrument modes. See [page 52](#) for further explanation of system features.

- **System** accesses features that control instrument configuration at the system level, like I/O configuration and alignment, which affect all instrument modes. Pressing **System** also returns the instrument to local control, if it has been in remote mode.
- **Preset** resets all parameters of the current mode back to the factory defaults.
- **Print** immediately prints what is on the screen to the printer, or saves a file to a floppy disc, according to the parameters that are currently set in the **Print Setup** menu. See [page 73](#) for more detail.
- **Print Setup** configures the transmitter tester for printing to a printer, or saving an image file to the floppy disc drive, and also allows you to select the printer type.
- **File** accesses softkeys that control the file system of the transmitter tester for saving and loading instrument states. See [page 71](#) for more detail.
- **Save** saves the current instrument state in the **File** menu. See [page 71](#) for more detail.

8. Marker keys are used to obtain specific information about parts of the displayed measurement (for example, to identify the exact frequency of an offset). See [page 89](#) for more detail.

- **Marker** accesses softkeys that allow manual positioning of markers.
- **Search** automatically performs a peak search, and accesses softkeys that automatically position markers at preset locations on the trace (for example, to determine the difference between the amplitude of one peak and another).

9. Probe Power The probe power input supplies power for external probes; the three connectors are a ground, and a +15 V, and a -12.6 V connector. The probe power supplies power to high frequency probes and accessories, such as preamplifiers, that are used as accessories to the transmitter tester. The probe power provides a maximum of 150 mA.

10. RF Input The 50 Ω RF input allows for input of an external RF signal. The connector is a type N female, and is rated for a maximum input of +35 dBm for measuring a CW signal, and a maximum of 26 volts for a DC signal.

11. Data Entry keys are used to enter numeric values. Entries made using data entry keys will be visible in the active function area (see the section on annotation on [page 35](#) to locate the active function area).

- The **Enter** key is used to terminate numeric data where no units of measurement are being entered, or where you want to terminate with the default unit of measurement. For operations involving selection of a unit of measurement (for example, dB, dBm, Hz, s, degrees, radians), the **Units** softkey menu (explained below) is used to terminate numeric entries.
- **Units** softkeys are used to enter units of measurement. If the value you are entering is in units of measurement, the units softkey menu will automatically appear once you enter a digit. After entering the desired numeric value, you terminate the entry by pressing the appropriate units of measurement softkey.
- **Numeric** keys enter numeric values as indicated on the keys. In addition, decimal and positive and negative sign keys are available for your use.
- The **Step** keys (these are the up and down arrow keys) change numeric values in increments of the current step size.
- The **Backspace** key moves the cursor backwards one space and erases the character in that space. You can use the **Backspace** key to backspace characters in the active function area.
- The **RPG Knob** changes numeric values in increments of the current knob resolution.

12. Floppy Disk Drive. The floppy disk drive accepts 1.44 megabyte disks. For an explanation of the operation of the floppy disc drive see the Using Print Keys section on [page 73](#).

13. Softkeys Softkeys either activate a feature or access a further softkey menu. An arrow on the right side of a softkey label indicates that the key accesses a further menu. The softkey which is currently active is highlighted. Keys unavailable for use are greyed-out. If a softkey

menu has multiple pages, further pages will be accessed by pressing the **More** key which is the bottom key on any multi-page menu.

14. Return key The **Return** key exits the current menu and returns you to the previous menu. If you are on page one of a multi-page menu (a menu with a “More” key) the **Return** key will exit the multi-page menu. When you activate a different measurement, the return list is cleared. The **Return** key will not return you to the previously activated mode, nor will it alter any values you have entered on previous menus.

15. Navigation keys are used to move around in the display, and to return to the previous menu.

- The **Tab Left** feature is not implemented. This feature will be implemented with a future firmware update.
- The **Tab Right** feature is not implemented. This feature will be implemented with a future firmware update.
- The **Home** feature is not implemented. This feature will be implemented with a future firmware update.

16. Window keys are used to move to a different window in the display or to zoom the windows being displayed.

- The **Next Window** key switches between windows. When a single window is being viewed it switches to display the next window which is contained in the current multi-window display which, however, is not initially visible on the display. When viewing multiple windows, it activates the next window on the display. The active window is indicated by a yellow border.
- The **Zoom** key allows you to switch between a multiple-window screen and a full-size display of the window that is active.

- 17. Help key** The **Help** feature is not implemented. This feature will be implemented with a future firmware update.
- 18. On/Off** switch turns on the transmitter tester. A green LED will light below the **Power** switch when the instrument has been turned on. When in standby mode a yellow LED is visible above the **On/Off** switch.
- 19. Inputs** enable you to input one or more of the two following external signals.
- **I input and Q input.** These inputs are not operational. These features will be implemented with a future hardware modification and a firmware update.
 - **External Trigger input.** The external trigger allows external triggering of measurements. The external trigger accepts an external trigger signal between -5 and $+5$ V, and has a nominal impedance of > 10 k Ω . For more information on triggering, see [page 79](#).

Rear Panel Description

The diagram below illustrates all rear panel connections. For further explanation of labels found on the rear panel see the section on safety considerations on [page 50](#).

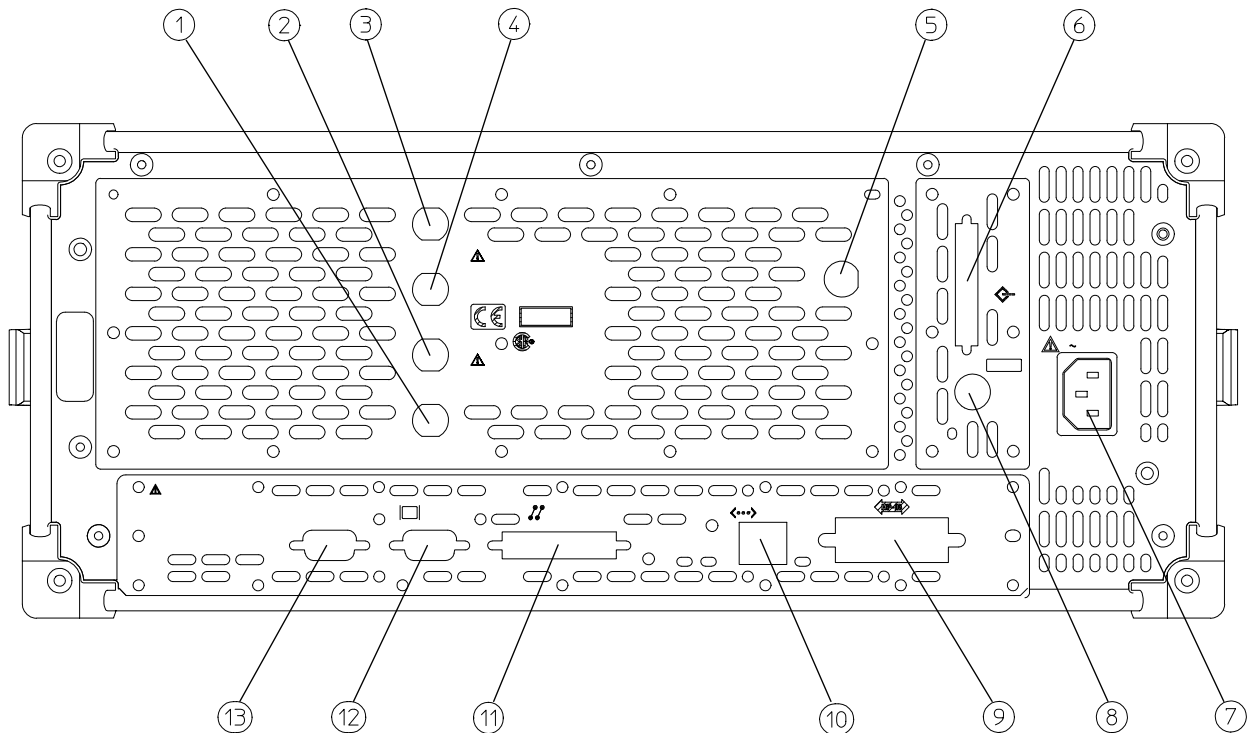

pa82a

- 1. TRIGGER 2 OUT** provides a transmitter tester trigger output. This is used to synchronize other test equipment with the transmitter tester.
- 2. TRIGGER 1 OUT** provides a transmitter tester trigger output. This is used to synchronize other test equipment with the transmitter tester.
- 3. EXT REF IN** allows the input of a 1 to 30 MHz external frequency reference signal. The external reference frequency must be entered by the user.

- 4. 10 MHz OUT** provides an output of the transmitter tester's internal 10 MHz frequency reference signal. This is used to lock the frequency reference of other test equipment with the transmitter tester. This is a switched output.
- 5. TRIGGER IN** The external trigger allows external triggering of measurements. The external trigger accepts an external trigger signal between -5 and $+5$ V, and has a nominal impedance of $10\text{k } \Omega$. For more information on triggering, see [page 79](#).
- 6. SCSI** Currently the **SCSI** connection can only be used to connect an external SCSI drive for firmware upgrades. SCSI functionality will be fully implemented with a future firmware update.
- 7. Line Power Input** AC power line connection. The line voltage operates at nominally 115 V (47 to 66 Hz) or at nominally 230 V (47 H to 66 Hz). The input power ranges for the power supply are 90 to 132 V or 195 to 250 Vrms. The power supply automatically senses the input power and switches between these two ranges. There is no customer replaceable power fuse. When on, the instrument consumes less than 350 W; when in standby less than 20 W.
- 8. KYBD** This feature is not implemented. This feature will be implemented with a future firmware update. The **KYBD** enables connection of an external PS-2 keyboard using a 6-pin mini-DIN connector. If no keyboard is available you can use the numeric keyboard and the **Alpha Editor** menu key feature to make the entries. The keyboard must be plugged into the instrument prior to powering the instrument on or the keyboard will not work.
- 9. GPIB** The **GPIB** allows the connection of a General Purpose Interface Bus (GPIB) cable, which enables remote instrument operation.

- 10. LAN-TP** The **LAN-TP** connector can be used:
- as a SICL server emulating IEEE 488.2 protocol over LAN.
 - for a telnet programming port that can be sent SCPI commands.
 - for a TCP/IP socket programming port that can be sent SCPI commands.
 - for anonymous FTP operations to retrieve a screen “gif” or screen “xwd” file from the ftp/pub.

NOTE

For more information on remote programming with your transmitter tester, refer to the programmer’s guide.

- 11. PARALLEL** The **PARALLEL** connection supports remote printing.
- 12. MONITOR** The **MONITOR** allows connection of an external VGA monitor, using a 15– pin mini D–SUB connector.
- 13. RS-232** The serial port **RS-232** is not implemented. This feature will be implemented with a future firmware update.

Display Annotation

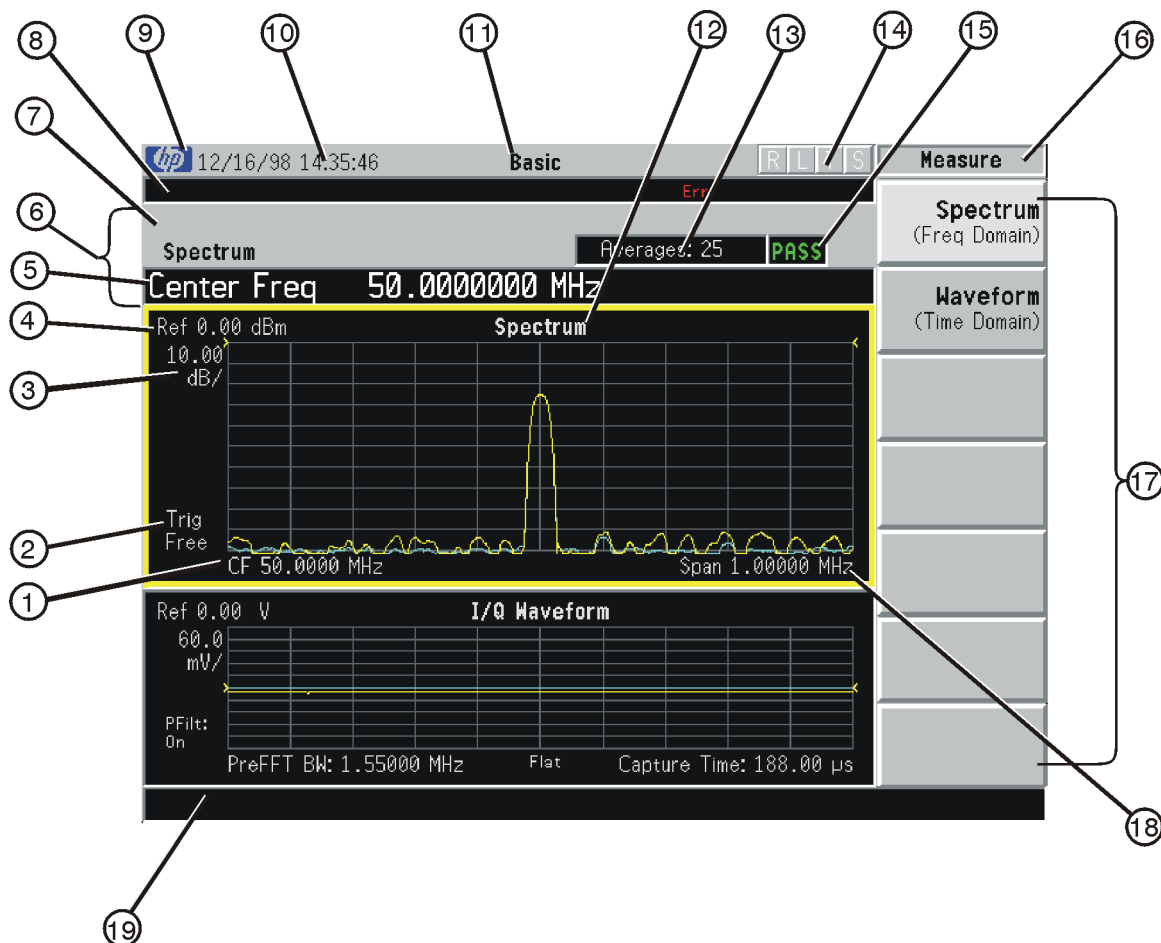

pa83a

The annotation features explained below refers to the display that is visible when your transmitter tester is in basic measurement mode; this is the default state of the transmitter tester when it is turned on. For explanations relating to unique measurement options such as GSM or cdmaOne see the documentation that accompanies each mode.

1. Center Frequency annotation.
2. Trigger Source Indicator.
3. Vertical Scale dB/Division Indicator.
4. Reference Level Indicator (in dBm).
5. Active Function Area. The active function area displays numeric entries. If you press a measurement key which activates a function, its value will appear in the active function area.

6. Measurement Bar. Displays information about measurements including some mode setup parameters.
7. Current Measurement Annotation.
8. The Annunciators bar displays annunciators that indicate that hardware errors, other errors, or specific instrument states, are detected in the instrument, as explained below. Error indicators are shown in red text. Where applicable, some states will appear in green, indicating that the feature is active and performing correctly. To view error messages fully you will use keys in the **Show Errors** menu (see [page 52](#)). The current error message with the highest priority will also appear in the Status/Info Bar that appears at the bottom of the display. The following annunciators are available:

UnLock - This annunciator indicates that one or more of the internal phase-locked loops are unable to maintain a phase-locked state.

Corr Off (corrections off) - This annunciator appears when the **Corrections** softkey is set to off.

Err (error) - This annunciator appears when an error message is placed in the history error queue. It will persist until you use the **Clear Error Queue(s)** key to clear the history error queue.

Ext Ref (external reference) - The green Ext Ref annunciator indicates that the external reference has been selected and the instrument is locked to it. The red Ext Ref annunciator indicates that the external reference has been selected, but the instrument is not locked to that reference. Note that the external reference on this instrument can be set at any frequency between 1 and 30 MHz; if the entered value does not correspond to the external reference that is in use, a red Ext Ref annunciator will appear.

NOTE

Be aware that the value entered for the external reference frequency will persist, even after the instrument has been powered off. The user must manually enter a new value for the external reference if a different value is required, even if it corresponds with the default value. An Ext Ref annunciator will appear only if the external reference has been activated by the user.

ESec (even second clock) - The green **E**Sec annunciator indicates that the external even second clock has been selected as the sync type and a sync signal is present at the even second input (rear panel Trigger In), and the measurement is using it as the demodulation sync type. The red **E**Sec annunciator indicates that an external even second clock has been selected as the sync type but a sync signal is not present at the even second input (rear panel Trigger In). In this case, the error message **Even Second Clock Missing** will appear in the Status/Info bar at the bottom of the display. The even second clock detection is updated every 2 seconds.

- 9.** System Bar.
- 10.** Time and Date.
- 11.** Personality Mode Indicator.
- 12.** Graph (Window) Title.
- 13.** Averaging Indicator.
- 14.** Remote Status Indicator. The remote status indicator contains four letters: “R”, “L”, “T”, and “S”. The current status is indicated by the letters that are highlighted. When highlighted, the “R” indicates that the instrument is in remote mode, the “L” indicates a listen state, the “T” indicates a talk state, and the “S” indicates a service request.
- 15.** Pass/Fail Status Indicator.
- 16.** Menu Title.
- 17.** Softkeys. A softkey that is currently active is highlighted. Greyed-out softkeys are unavailable and may require a password for use.
- 18.** Span annotation.
- 19.** Status/Info Bar. The current error message which has the highest priority will appear in the Status/Info Bar.

Installing Optional Measurement Personalities

When you **Install** a measurement personality, you follow a two step process.

1. The measurement personality firmware must be installed into the instrument. (See the supplied installation instructions.)
2. A license key number must be entered which enables the measurement personality to run. (Refer to the “License Key Numbers” section below.)

Adding additional measurement personalities requires purchasing a retrofit kit for the desired option. The retrofit kit includes the measurement personality firmware, usually supplied on a zip disk. The license key certificate, included in the kit, contains the license key number. Every retrofit kit will have installation instructions.

The installation instructions require you to know three pieces of information about your instrument: the amount of memory installed, the Host ID, and the instrument serial number.

Required information:	Key Path:
Instrument Memory: _____	System, File System (the amount of memory in your instrument will be the sum of the <i>Used</i> memory and the <i>Free</i> memory)
Host ID: _____	System, Show System, Host ID
Instrument Serial Number: _____	System, Show System, Serial Number

The **Exit Main Firmware** key is used during the firmware installation process. This key is only for use when you want to update firmware using a LAN connection. The **Exit Main Firmware** key halts the operation of the resident firmware code so you can install an updated version of firmware using a LAN connection. Instructions for loading future firmware updates are available at the following URL:

www.agilent.com/find/vsa/

Available Personality Options

The option designation consists of three characters, as shown in the **Option** column of the table below.

Available Personality Options ^a	Option
GSM with EDGE, measurement personality	BAH
cdmaOne measurement personality	BAC
NADC, PDC measurement personalities	BAE
iDEN measurement personality	HN1
W-CDMA measurement personality	BAF
cdma2000 measurement personality	B78

a. As of the print date of this measurement guide.

License Key Numbers

The measurement personality you have purchased with your instrument has been installed and enabled at the factory. With the purchase of the measurement personality, and with any future purchase of a new personality, you will receive a unique license key number. The license key number is a hexadecimal number that is for your specific measurement personality and instrument serial number. The license key enables you to install, or reactivate any personality you have purchased.

Follow these steps to locate the unique license key number for the measurement personality that has come installed in your instrument:

1. Press **System, More (1 of 3), More (2 of 3), Install, Choose Option**. When you press the **Choose Option** key the alpha editor will be activated. Use the alpha editor to enter the letters (upper-case) and the front-panel numeric keyboard to enter the numbers (if required) for the personality option that has been installed in the instrument.
2. Press the **Done** key on the alpha editor menu. The unique license key number for your instrument will now appear on the **License Key** softkey.

You will want to keep a copy of your license key number in a secure location. Please enter your license key numbers in the box provided below for future reference. If you should lose your license key number, call your nearest Agilent Technologies service or sales office for assistance.

License Key Numbers for Instrument with Serial # _____	
For Option _____	the license key number is _____
For Option _____	the license key number is _____
For Option _____	the license key number is _____
For Option _____	the license key number is _____
For Option _____	the license key number is _____
For Option _____	the license key number is _____

If you purchase an option later, you will receive a certificate which displays the unique license key number that you will need to install that option.

NOTE

You will need to use a license key number only if you purchase an additional measurement personality, or if you want to reactivate a measurement personality that has been deactivated.

Installing a License Key Number

NOTE

Follow this procedure to reinstall a license key number which has been deleted during the uninstall process, or lost due to a memory failure.

To install a license key number for the selected option, use the following procedure:

1. Press **System, More(1 of 3), More(2 of 3), Install, Choose Option**. Pressing the **Choose Option** key will activate the alpha editor menu. Use the alpha editor to enter the letters (upper-case) and the front-panel numeric keyboard to enter the numbers (if required) for the option designation, then press the **Done** key. As you enter the option, you will see your entry in the active function area of the display.
2. Press **License Key**. Entering the license key number will require entry of both letters and numbers. Use the alpha editor to enter letters. Use the front-panel numeric keyboard to enter numbers. You will see your entry in the active function area of the display. When you have completed entering the license key number, press the **Done** key.

3. Press the **Install Now** key after you have entered the active license key number and the personality option. When pressed, a message may appear in the function area of the display which reads, "Insert disk and power cycle the instrument". Disregard this message. Press the **No** key only if you wish to cancel the installation process. If you want to proceed with the installation, press the **Yes** key and cycle the instrument power off and then on.

Using the Uninstall Key

The following procedure removes the license key number for the selected option. This will make the option unavailable for use, and the message "Application Not Licensed" will appear in the Status/Info bar at the bottom of the display. Please write down the 12-digit license key number for the option before proceeding. If that measurement personality is to be used at a later date you will need the license key number to reactivate the personality firmware.

NOTE

Using the **Uninstall** key does not remove the personality from the instrument memory, and does not free memory to be available to install another option. If you need to free memory to install another option, refer to the instructions for loading firmware updates located at the URL: www.agilent.com/find/vsa/

1. Press **System, More(1 of 3), More(2 of 3), Uninstall, Choose Option**. Pressing the **Choose Option** key will activate the alpha editor menu. Use the alpha editor to enter the letters (upper-case) and the front-panel numeric keyboard to enter the numbers (if required) for the option, then press the **Done** key. As you enter the option, you will see your entry in the active function area of the display.
2. Press the **Uninstall Now** key after you have entered the personality option. Press the **No** key only if you wish to cancel the uninstall process. Press the **Yes** key if you want to continue the uninstall process.
3. Cycle the instrument power off and then on to complete the uninstall process.

Cables for Connecting to the Serial Port (RS-232)

There are a variety of cables and adapters available for connecting to PCs, and printers. Several of these are documented in the following wiring diagrams. You need to find out what connections your equipment uses to identify the cables and/or adapters that you will need.

34398A

RS-232

Cable Kit

This kit comes with an RS-232, 9-pin female to 9-pin female null modem/printer cable and one adapter 9-pin male to 25-pin female (part number 5181-6641). The adapter is also included in 34399A RS-232 Adapter Kit.

34399A

RS-232

Adapter Kit

This kit includes four adapters to go from DB9 female cable (34398A) to PC/printer DB25 male or female, or to modem DB9 female or DB25 female.

Figure 1-5

24542U Cable

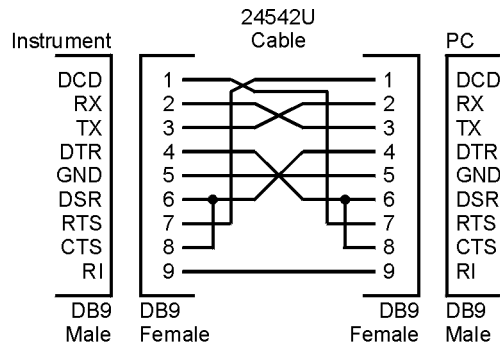

ca85a

Figure 1-6

F1047-80002 Cable

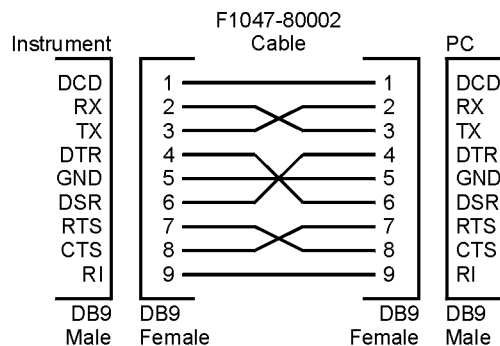

ca86a

Figure 1-7 24542G/H Cable

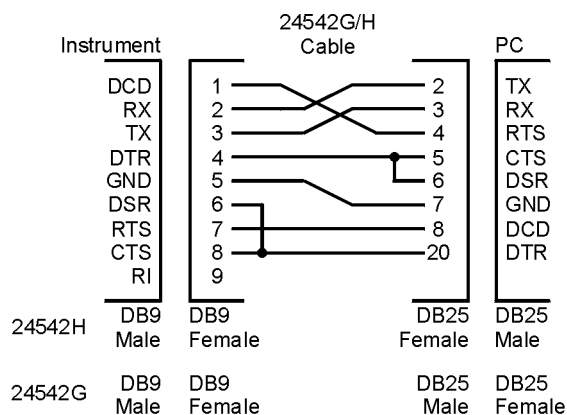

ca87a

Figure 1-8 92219J Cable

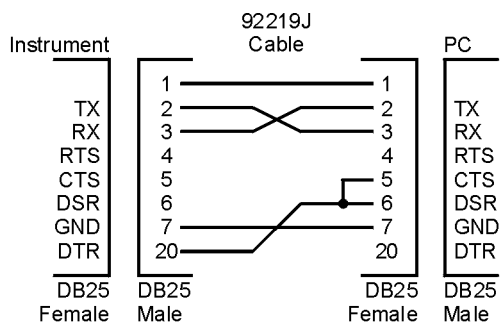

ca83a

Figure 1-9 13242G Cable

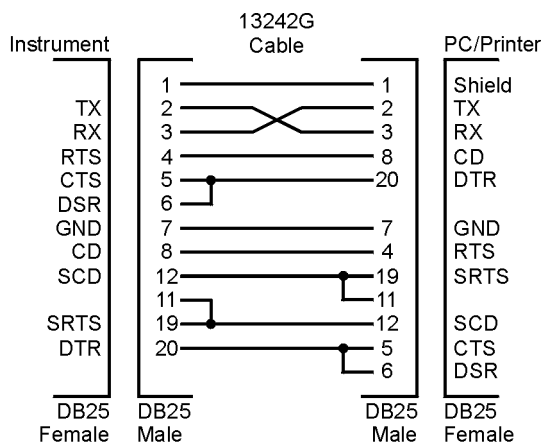

ca84a

Figure 1-10 24542M Modem Cable

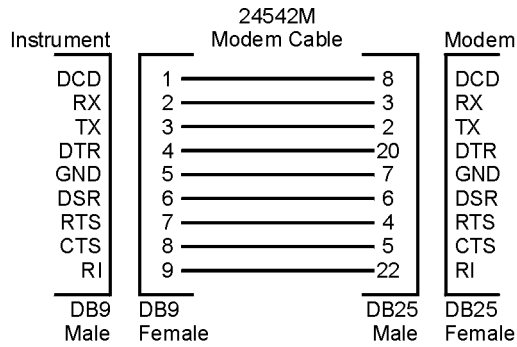

ca88a

Figure 1-11 C2913A/C2914A Cable

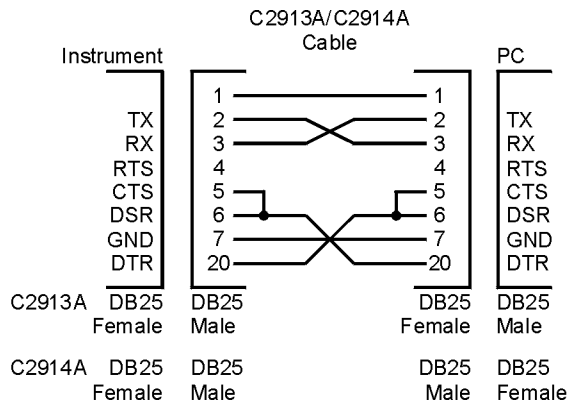

ca89a

Figure 1-12 Mouse Adapter (typical)

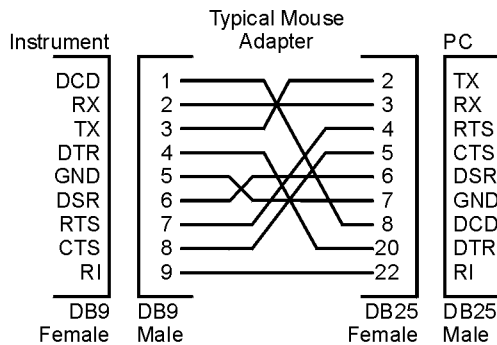

A mouse adapter works well as a 9 pin to 25 pin adapter with a PC.

ca810a

Figure 1-13 24542U Cable with 5181-6641 Adapter

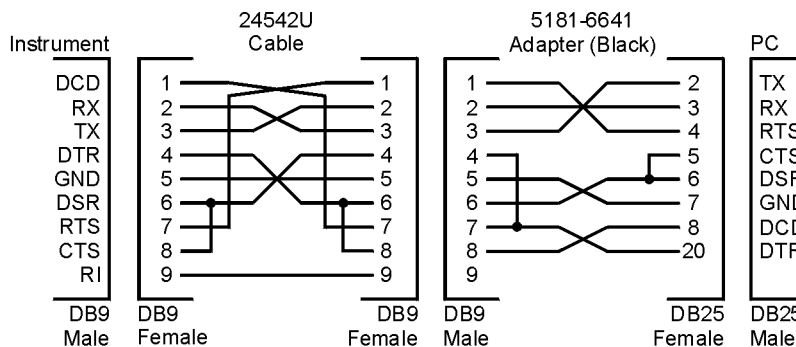

ca811a

Figure 1-14 24542U Cable with 5181-6640 Adapter

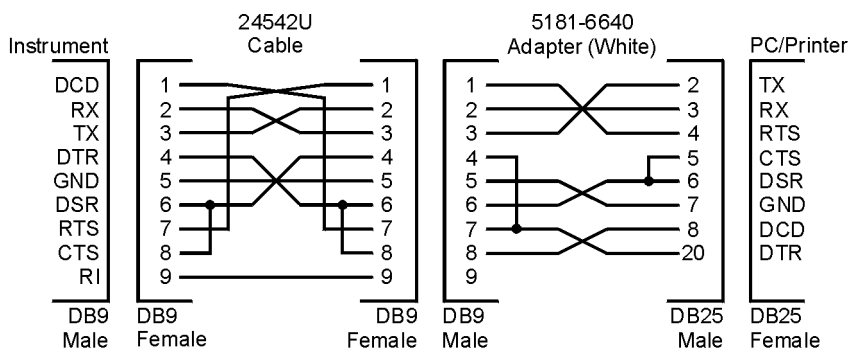

ca812a

Figure 1-15 24542U Cable with 5181-6642 Adapter

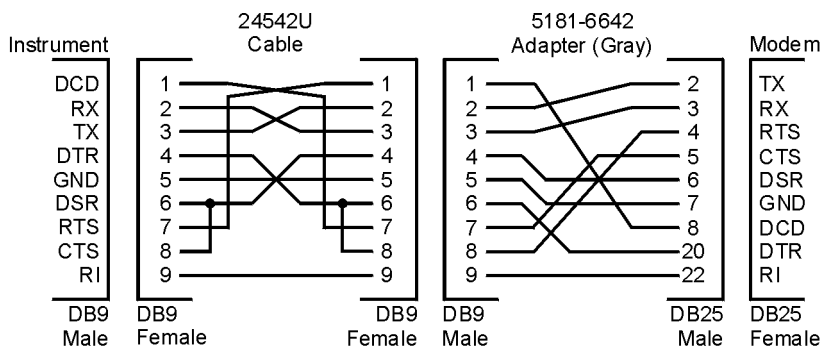

ca813a

Figure 1-16 24542U Cable with 5181-6639 Adapter

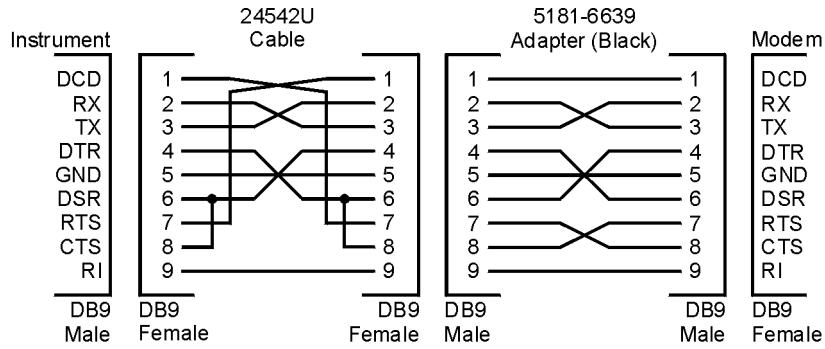

ca814a

Figure 1-17 F1047-80002 Cable with 5181-6641 Adapter

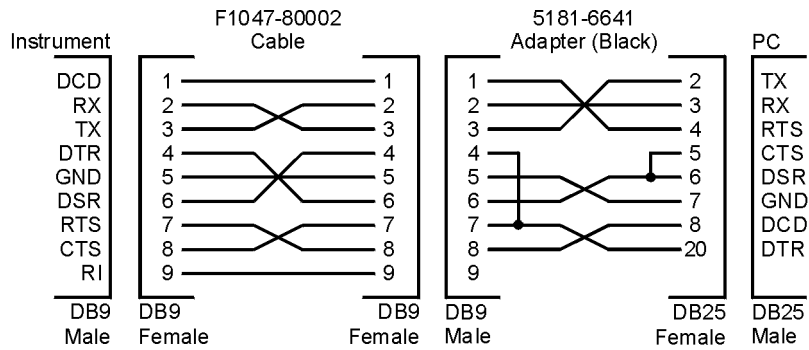

ca815a

Figure 1-18 F1047-80002 Cable with 5181-6640 Adapter

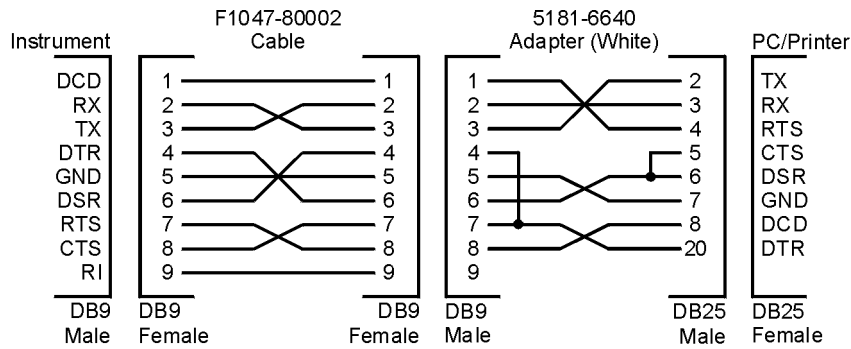

ca816a

Figure 1-19 F1047-80002 Cable with 5181-6642 Adapter

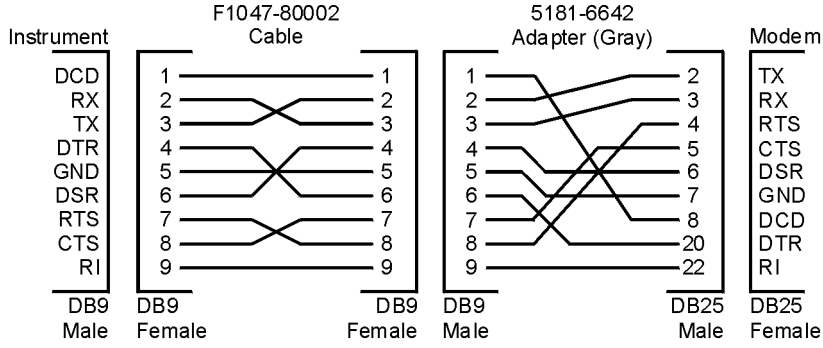

ca817a

Figure 1-20 F1047-80002 Cable with 5181-6639 Adapter

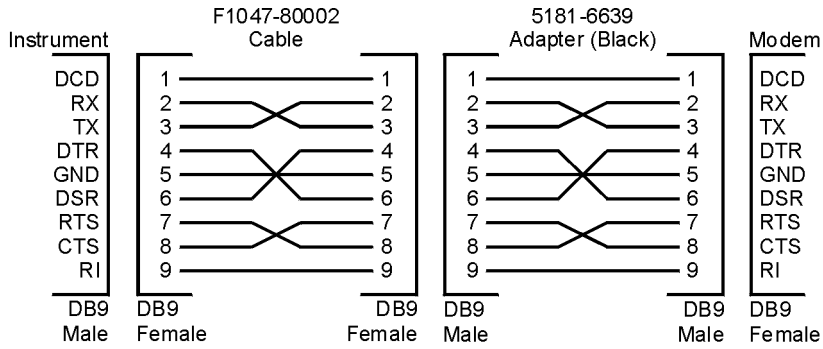

ca818a

Safety Considerations

This section covers safety considerations relating to the installation and use of the instrument.

Instrument Installation

Install the instrument so that the detachable power cord is readily identifiable and is easily reached by the operator. The detachable power cord is used to completely disconnect the instrument. The front panel switch is only a standby switch which maintains standby power to some parts of the instrument. It does not disconnect the instrument from the power source. Alternatively, an externally installed switch or circuit breaker (which is readily identifiable and is easily reached by the operator) may be used as a disconnecting device.

The input power ranges for the power supply are 90 to 132 V, or 195 to 250 Vrms. The power supply automatically senses the input power and switches between these two ranges. There is no customer replaceable power fuse.

WARNING

The power cord is connected to internal capacitors that may remain live for 5 seconds after the plug is disconnected from its power supply.

WARNING

If this product is to be energized via an external autotransformer for voltage reduction, make sure that its common terminal is connected to a neutral (earthed pole) of the power supply.

CAUTION

This instrument has autoranging line voltage input, be sure the supply voltage is within the specified range.

CAUTION

VENTILATION REQUIREMENTS: When installing the product in a cabinet, the convection into and out of the product must not be restricted. The ambient temperature (outside the cabinet) must be less than the maximum operating temperature of the product by 4° C for every 100 watts dissipated in the cabinet. If the total power dissipated in the cabinet is greater than 800 watts, then forced convection must be used.

Instrument Operation and Maintenance

The following warnings explain conditions which affect the safe operation of the instrument.

WARNING **If this instrument is not used as specified, the protection provided by the equipment could be impaired. This product must be used in a normal condition (in which all means for protection are in tact) only.**

WARNING **To prevent electrical shock, disconnect the E4406A from mains before cleaning. Use a dry cloth or one slightly dampened with water to clean the external case parts. Do not attempt to clean internally.**

Explanation of Safety Symbols that are on the Instrument

The following list describes all safety symbols that are on the front and rear panels of the transmitter tester.



The instruction documentation symbol. The product is marked with this symbol when it is necessary for the user to refer to the instructions in the documentation.



This symbol is used to mark the ON position of the power line switch.



This symbol is used to mark the OFF position of the power line switch.



This symbol is used to mark the STANDBY position of the power line switch.



This symbol indicates that the input power required is AC.



This symbol is used to mark the STANDBY/OFF position of the power line switch.



This symbol is used to mark the On position of the power line switch.

Safety Considerations for Service Personnel

NOTE

No one other than qualified service personnel are allowed to remove the cover of the instrument. The following warnings apply to service personnel. These warnings are found on the rear panel of the instrument.



To Remove Outer Cover, Remove Strap Handle, 4 Bottom Feet, and 4 Rear Feet.



To Remove CPU Assembly Unplug All Boards Connected to CPU. When Removing CPU Keep Perpendicular with Rear Panel

Using System Keys

System features are accessed through the **System** front panel key. These are features that are not dependent on the currently selected application mode or the particular measurement being made. They apply to all modes and measurements. The **System** key also performs the LOCAL function reactivating the front panel keys if the instrument was previously in the remote mode being controlled by an external computer.

File feature keys are accessed through the **File** and **Save** menu keys, which are explained on [page 71](#).

Print feature keys are accessed through the front panel **Print Setup** menu key and the **Print** key, which are explained on [page 73](#).

Each description of a system feature begins with a table showing the key path for all keys related to that feature.

NOTE

Most of the System keys are not affected by pressing the **Preset** key or by cycling the instrument power. These features will stay at the last value set by the user. Press **System**, **More**, **Restore Sys Defaults**, **Yes** to reset the System parameters back to the factory defaults.

Install and Uninstall

The **Install** and **Uninstall** keys are described on [page 38](#) of the Getting Started chapter.

Key Locations

All instrument features can be located by using the key access table below. The key access path describes the key sequence you enter to access the particular key. Some features can only be used when specific measurements are active. If a feature is not currently valid it will appear as lighter colored text or it will not be displayed at all.

The keys listed in this table cover system, service, and basic features.

Table 2-1 Key Access Locations

Key	Key Access Path
10 MHz Out	System/Reference/
50 MHz Amptd	MODE/Service/
50 MHz Ref	Input/Input Port/
ADC Dither	Meas Setup/More(1 of 2)/Advanced/ More(1 of 2)/
ADC Range	Meas Setup/More(1 of 2) / Advanced / Note: This feature is used when measure is set to either spectrum or waveform.
Adjust Now	System/Alignments/Align Subsystem/Align 50 MHz Reference/ Note: Requires Password
Advanced	Meas Setup/More(1 of 2)
Align 50 MHz Reference	System/Alignments/Align Subsystem/ Note: Requires Password
Align ADC	System/Alignments/Align Subsystem/
Align All Now	System/Alignments/
Align IF	System/Alignments/Align Subsystem/
Align RF	System/Alignments/Align Subsystem/
Alignments	System/
Align Subsystems	System/Alignments/
All	View/Trace/Trace Display/
Alpha Editor	The Alpha Editor is accessed by following the Menu Access Paths that accompany the following key entries: Choose Option, License Key, and Host Name.
AMPLITUDE/ Y Scale	Front Panel

Table 2-1 Key Access Locations

Key	Key Access Path
Auto	Meas Setup/More(1 of 2)/Advanced/ More (1 of 2)/Data Packing/
Auto	Meas Setup/More(1 of 2)/ Advanced /ADC Range / Note: This feature is used when measurement is set to either spectrum or waveform.
Auto Align	System/Alignments/
AutoPeak	Meas Setup/More(1 of 2)/ Advanced /ADC Range / Note: This feature is used when measurement is set to either spectrum or waveform.
AutoPeakLock	Meas Setup/More(1 of 2)/ Advanced /ADC Range / Note: This feature is used when measurement is set to either spectrum or waveform.
Auto Trig	Mode Setup/ Trigger/ Note: This feature is used when measurement is set to either spectrum or waveform.
Average	View/Traces/ Display Traces/
Average	Meas Setup/ Note: This feature is used when measurement is set to either spectrum or waveform.
Avg Mode	Meas Setup/ Average/ Note: This feature is used when measurement is set to either spectrum or waveform.
Avg Number	Meas Setup/Average/ Note: This feature is used when measurement is set to either spectrum or waveform.
Avg Trace	Marker/More(1 of 2)/ Marker Trace/
Avg Type	Meas Setup/ Average/ Note: This feature is used when measurement is set to either spectrum or waveform.
Band Power	Marker/ Function/
I/Q	Input/Input Port/
Basic	MODE/
Blackman	Meas Setup/More(1 of 2)/ Advanced/ FFT Window/
Blackman- Harris	Meas Setup/More(1 of 2) /Advanced / FFT Window/ More(1 of 2)/
cdmaOne	MODE/
Center Freq	FREQUENCY/Channel/
Choose Option	System/More(1 of 3)/More(2 of 3) /Install/

Table 2-1 Key Access Locations

Key	Key Access Path
Choose Option	System/More(1 of 3)/More(2 of 3) /Uninstall/
Clear Error Queue(s)	System/Show Errors/
Comb	Input/IF Align Signal/Signal Type/
Config I/O	System/
Corrections	System/Alignments/
Current	View/Trace/ Trace Display/
Current Trace	Marker/ More(1 of 2)/Marker Trace/
CW	Input/IF Align Signal/Signal Type/
Data Packing	Meas Setup/More(1 of 2)/
Decimation	Meas Setup/More(1 of 2)/ Advanced/More (1 of 2)/
Delay	Mode Setup/Trigger/Ext Front/
Delay	Mode Setup/Trigger/Ext Rear/
Delay	Mode Setup/Trigger/RF Burst/
Delay	Mode Setup/Trigger/Video/
Delta	Marker/
Diagnostics	System/More (1 of 3)/ Note: Requires Password
Display	Front Panel
Emulated GPIB Name	System/Config I/O/ SICL Server
Emulated GPIB Logical Unit	System/Config I/O/ SICL Server
Emulated GPIB Address	System/Config I/O/ SICL Server
Enter	Front Panel
ESC	Front Panel
Exit Main Firmware	System/ More (1 of 3)/More (2 of 3)/ Install/
Ext Front	Mode Setup/ Trigger/
Ext Rear	Mode Setup/ Trigger/
FFT Length	Meas Setup/More(1 of 2)/ Advanced/FFT Size/ Note: This feature is used when measurement is set to spectrum.

Table 2-1 Key Access Locations

Key	Key Access Path
FFT Size	Meas Setup/ More(1 of 2)/ Advanced/ Note: This feature is used when measurement is set to spectrum.
FFT Window	Meas Setup/ More(1 of 2)/ Advanced/ Note: This feature is used when measurement is set to spectrum.
File	Front Panel
File System	System/More(1 of 3)/ More(2 of 3)/
File Type	Print Setup/
Flat Top	Meas Setup/More(1 of 2)/ Advanced/ FFT Window/
Free Run	Meas Setup//Trig Source/
FREQUENCY/ Channel	Front Panel
Freq Ref	System/ Reference/
Front Panel Test	MODE/Service/More(1 of 2)/
Function	Marker/ More(1 of 2)/
Gaussian	Meas Setup/More(1 of 2) /Advanced / FFT Window/
GSM	MODE/
Hamming	Meas Setup/More(1 of 2) /Advanced / FFT Window/
Hanning	Meas Setup/More(1 of 2) Advanced / FFT Window/
Help	Front Panel
Host Name	System/Config I/O/
GPIO Address	System/Config I/O/
IF Align	Input/ Input Port/
IF Align Signal	Input/
Instrument Name	System/Config I/O/ SICL Server
Instrument Logical Unit	System/Config I/O/ SICL Server
Input	Front Panel
Input Atten	Input/
Input Port	Input/
Install	System/More(1 of 3)/ More(2 of 3)/
Install Now	System/ More (1 of 3)/ More (2 of 3)/ Install/

Table 2-1 Key Access Locations

Key	Key Access Path
IP Address	System/Config I/O/
I/Q Input Z	Input/
I/Q Waveform	Marker/Trace/ Note: This feature is used when measurement is set to either spectrum or waveform.
K-B 70 dB	Meas Setup/More(1 of 2)/ Advanced / FFT Window/More(1 of 2)/
K-B 90 dB	Meas Setup/More(1 of 2)/ Advanced / FFT Window/More(1 of 2)/
K-B 110 dB	Meas Setup/More(1 of 2)/ Advanced / FFT Window/More(1 of 2)/
Length Ctrl	Meas Setup/More(1 of 2)/ Advanced/FFT Size/ Note: This feature is used when measurement is set to spectrum.
Level	Mode Setup/Trigger/Ext Front/
Level	Mode Setup/Trigger/Ext Rear/
License Key	System/ More (1 of 3)/ More (2 of 3)/ Install/
Line	Meas Setup/ Trig Source/
Load State	File/
Local (System)	Note: Press the front panel System key to change from remote to local control of the instrument
Log-Pwr Avg	Meas Setup/Average/Avg Type/
Long	Meas Setup/More(1 of 2)/ Advanced/ More (1 of 2)/ Data Packing/
Manual	Meas Setup/More(1 of 2)/ Advanced /ADC Range/ Note: This feature is used when measurement is set to either spectrum or waveform.
Marker	Front Panel
Maximum Connections	System/Config I/O/ SICL Server
Mrkr All Off	Marker/More(1 of 2)/
Maximum	Meas Setup/ Average/ Avg Type/
Max Total Pwr	Input/
Measure	Front Panel
Meas Control	Front Panel
Meas Setup	Front Panel

Table 2-1 Key Access Locations

Key	Key Access Path
Medium	Meas Setup/More(1 of 2)/Advanced/ More (1 of 2)/Data Packing/
Minimum	Meas Setup/Average/ Avg Type/
Min Pnts/ RBW	Meas Setup/More(1 of 2)/ Advanced/FFT Size/ Note: This feature is used when measurement is set to spectrum.
MODE	Front Panel
Mode Setup	Front Panel
Next Window	Front Panel
Noise	Marker/ Function/
Normal	Marker/
Off	Marker/
Pause	Meas Control
Peak Level	Mode Setup/ Trigger/ RF Burst/
Pre-ADC BPF	Meas Setup/ More(1 of 2)/ Advanced/ Note: This feature is used when measurement is set to either spectrum or waveform.
Pre-FFT BW	Meas Setup/ More(1 of 2)/ Advanced/ Note: This feature is used when measurement is set to spectrum.
Pre-FFT Fltr	Meas Setup/ More(1 of 2)/ Advanced/ Note: This feature is used when measurement is set to spectrum.
Print	Front Panel
Printer	Print Setup/
Print Setup	Front Panel
Print To	Print Setup/
Pulse	Input/IF Align Signal/Signal Type/
Pwr Avg (RMS)	Meas Setup/Average/Avg Type/
Pwr vs Time	MODE/Service/
RBW Filter	Meas Setup/ More(1 of 2)/ Advanced Note: This feature is used when measurement is set to spectrum.
Reference	System/
Ref Position	AMPLITUDE/Y Scale/ for spectrum or waveform - or - SPAN/XScale/ for waveform.
Ref Values	AMPLITUDE/Y Scale/ for spectrum or waveform - or - SPAN/XScale/ for waveform.

Table 2-1 Key Access Locations

Key	Key Access Path
Res BW	Meas Setup/ Note: This feature is used when measurement is set to either spectrum or waveform.
Restart	Front Panel
Restore Align Defaults	System/Alignments/
Restore Meas Defaults	Meas Setup/ More(1 of 2)
Restore Sys Defaults	System/ More(1 of 3)/ More (2 of 3) /
Return	Front Panel
RF	Input/Input Port/
Align RF	System/Alignments/Align Subsystem/
RF Burst	Mode Setup/ Trigger/
RF Envelope	View/Trace/ Note: This feature is used when measurement is set to waveform.
RF Envelope	Marker/Trace/ Note: This feature is used when measurement is set to waveform.
RF Inp Level	System/Alignments/Align Subsystem/ Align 50 MHz Reference/
Save	Front Panel
Save State	File/ or Save/
Scale Coupling	AMPLITUDE/Y Scale/ for spectrum or waveform - or - SPAN/XScale/ for waveform.
Scale/Div	AMPLITUDE/Y Scale/ for spectrum or waveform - or - SPAN/XScale/ for waveform.
SCPI Lan	System/Config I/O/
Search	Front Panel
Select	Marker/
Sensors	MODE/Service/
Server	System/Config I/O/ SICL Server
Service	MODE/
Service Password	System/More(1 of 3)/Show System/

Table 2-1 Key Access Locations

Key	Key Access Path
Shape	Marker/More (1 of 2)/
Short	Meas Setup/More(1 of 2)/ Advanced/More (1 of 2)/Data Packing/
Show Errors	System/
Show System	System/More(1 of 3)/
SICL Server	System/Config I/O/
Signal Amptd	Input/IF Align Signal/
Signal Rate	Input/IF Align Signal/
Signal Type	Input/IF Align Signal/
Slope	Mode Setup/Trigger/Ext Front
Slope	Mode Setup/Trigger/Ext Rear/
Slope	Mode Setup/Trigger/RF Burst/
Slope	Mode Setup/Trigger/Video/
Socket Port	System/Config I/O/ SCPI Lan
Span	Meas Setup/
SPAN/ X Scale	Front Panel
Spectrum	View/Trace/ Note: This feature is used when measurement is set to spectrum.
Spectrum	Marker/Trace/ Note: This feature is used when measurement is set to spectrum.
Spectrum Avg	Marker/Trace/ Note: This feature is used when measurement is set to spectrum.
Spectrum (Freq Domain)	MODE/Service/
Spectrum (Freq Domain)	MODE/Basic/
Store Abs Ampl to EEROM	System/Alignments/Align Subsystem/ Align 50 MHz Reference/
Sweep Time	Meas Setup/ Can be accessed when measure is set to waveform.
System	Front Panel
Telnet Port	System/Config I/O/ SCPI Lan
Timebase Freq	MODE/Service/

Table 2-1 Key Access Locations

Key	Key Access Path
Trace	Marker/
Trace Display	View/Trace/
Trigger	Mode Setup/ Note: This feature is used when measurement is set to either spectrum or waveform.
Trig Holdoff	Mode Setup/ Trigger/ Note: This feature is used when measurement is set to either spectrum or waveform.
Trig Source	Meas Setup/ Note: This feature is used when measurement is set to either spectrum or waveform.
Uniform	Meas Setup/More(1 of 2)/Advanced / FFT Window/
Uninstall	System/ More (1 of 3)/ More (2 of 3)/
Uninstall Now	System/ More (1 of 3)/ More (2 of 3)/ Uninstall/
Video	Mode Setup/ Trigger/
View/Trace	Front Panel
Visible Align	System/Alignments/
Voltage Avg	Meas Setup/Average/ Avg Type/
Waveform (Time Domain)	MODE/Basic/
Waveform (Time Domain)	MODE/Service/
WindowLength	Meas Setup/More(1 of 2)/ Advanced/FFT Size/ Note: This feature is used when measurement is set to spectrum.
Zoom	Front Panel

Using I/O, Front and Rear Panel Keys

There are several keys available to help configure the instrument inputs/outputs. These include the various buses, external reference, and other types of I/O.

Configuring I/O

Press **System**, **Config I/O** to access keys and menus that enable you to identify and change the current GPIB address, to identify and change various LAN settings.

Front Panel Key	Level 1	Level 2	Level 3/Entry
System	Config I/O	GPIB Address	
		IP Address	
		Host Name	Alpha Editor
		Ethernet Addr	
		SCPI LAN	Telnet Port
			Socket Port
		SICL Server	Server
			Maximum Connections
			Instrument Name
			Instrument Logical Unit
			Emulated GPIB Name
			Emulated GPIB Logical Unit
			Emulated GPIB Address

- **GPIB Address** - Shows the current GPIB address (18 is the default setting) and allows you to change this value. The new value is displayed in the active function area. The GPIB port is always active.
- **IP Address** - Changes the IP address of the instrument. The address is composed of numbers and decimal points as required by your LAN system.

- **Host Name** - Displays the host name of the instrument. Pressing the key activates the alpha editor, which enables you to change the host name.
- **Ethernet Addr** - Shows the Ethernet address. This is an information only feature that can not be modified by the user.
- **SCPI Lan** - Accesses the following keys:
 - Telnet Port** - Turns on or off telnet programming over the LAN. This key only affects new connections, not existing connections. Enter the port number that you will use for your telnet connection to the transmitter tester. The default port number is 5023.
 - Socket Port** - Turns on or off socket programming over the LAN. This key only affects new connections, not existing connections. Enter the port number that you will use for your socket connection to the transmitter tester. The default port number is 5025.
- **SICL Server** - Accesses the following keys. These keys are provided for information only. The “value” of the settings cannot be changed.
 - Server** - Indicates the on/off condition of the SICL IEEE 488.2 protocol LAN server.
 - Maximum Connections** - Shows you the maximum number of connections that can be accessed simultaneously. The default is 5.
 - Instrument Name** - Shows you the name, (same as the remote SICL address), of your transmitter tester. The default is `instr0`.
 - Instrument Logical Unit** - Shows you the unique integer assigned to your transmitter tester when using SICL LAN. The default is 8.
 - Emulated GPIB Name** - Shows you the name, (same as the remote SICL address), of the device used when communicating with your transmitter tester. The default is `gpib7`.
 - Emulated GPIB Logical Unit** - Shows you the unique integer assigned to your device when it is being controlled using SICL LAN. The default is 8.
 - Emulated GPIB Address** - Shows you the emulated GPIB address assigned to your transmitter tester when it is a SICL server. This address is set using the **GPIB Address** key.

NOTE

For more information these and other remote programming features, refer to the programmer’s guide for your transmitter tester.

- **File System** - Shows the current amount of `Used` memory and `Free` memory in units of megabyte (MB).

Reference

Press the **Reference** menu key to activate a menu which allows you to select an external reference, or to deactivate a 10 MHz out signal on the rear panel.

Front Panel Key	Level 1	Level 2	Toggle	Entry
System	Reference	Freq Ref	Int/Ext	When toggled to Ext, enter any value between 1 and 30 MHz
		10 MHz Out	Off/On	

- **Freq Ref** - Allows you to select an external or an internal (the default) reference. When toggled to Ext (external) you will set the external reference frequency by entering a value between 1 and 30 MHz. When the instrument is locked to an external reference a green Ext Ref indicator will appear in the annunciator bar.

External reference values are persistent. This means that the external reference frequency you select will remain active until it is changed, even if the instrument is turned off and on, or preset. If the frequency you have input to the rear panel external frequency connector is not the same as the external frequency value you have manually set, a red Ext Ref error indicator and a red Unlock error indicator will appear in the annunciator bar.

- **10 MHz Out** - Activates, or deactivates, the 10 MHz out signal on the rear panel of the instrument. The 10 MHz out can be used to lock other test equipment to the same frequency reference that is used by the transmitter tester. Once activated, the 10 MHz out feature is persistent, so if it is set to On it will remain on, even if the instrument has been preset, or powered off and then on.

Using Alignment & Configuration Keys

There are number of different keys that can help you with understanding the current instrument configuration and for hardware alignment.

NOTE

Some features are intended for use only by service personnel and cannot be accessed without a service password. If after pressing a key a message appears requesting entry of a password, you should understand this to indicate that this feature is meant for service use only. The password is not available unless the user has purchased the service guide.

Alignment

Press **System, Alignments** to access menus which enable you to align the instrument. Press the **ESC** key to stop any alignment. The table below diagrams the paths through which you will access alignment feature keys. The feature in the cell that is greyed-out requires a password.

Front Panel Key	Level 1	Level 2	Level 3
System	Alignments	Auto Align	On/Alert/Off
		Align All Now	
		Align Subsystems	Align RF
			Align IF
			Align ADC
			Align 50 MHz Reference
			Align Current IF Flatness
			Align Current Sysgain
		Corrections	On/Off
		Time Corr	Auto/On/Off
		Restore AlignDefaults	
		Visible Align	Off/Low/High

- **Auto Align** - Defaults to the alert state. When set to Alert, the auto align feature causes a message to appear once during every 24 hours of instrument operation to alert the user that the instrument needs to be aligned. This message will also appear if the instrument detects that an alignment is needed, for example if there is a change of ambient temperature greater than $\pm 3^\circ \text{C}$. When set to the On state a background alignment, which slows down the measurement, occurs once during every 24 hour period or occurs automatically, when a change in ambient temperature greater than $\pm 3^\circ \text{C}$ has occurred. When set to Off, no auto alignments are done and no Alignment Needed message will appear.
- **Align All Now** - Immediately activates an alignment on all of the instrument's standard RF, IF, and ADC alignments. All other operations are stopped and the alignments will be visible on the display.
- **Align Subsystem** - Allows you to activate one or a group of the standard internal instrument alignments. It allows service personnel to perform an alignment to set the amplitude of the internal 50 MHz reference signal for absolute amplitude accuracy.

It allows you to perform alignments on circuitry relating to the following internal alignments. Press the **ESC** key to cause any alignment to stop.

Align RF - Activates an alignment on the RF circuitry.

Align IF - Activates an alignment on the IF circuitry. The main gain of the Analog IF is used to compensate for prefilter BW gain variations so the gain of the entire IF path before the A/D remains constant.

Align ADC - Activates an alignment on the ADC circuitry.

Align 50 MHz Reference - Enables a service technician to adjust the amplitude of the internal 50 MHz reference signal. The test equipment and the adjustment procedure required are described in the E4406A service guide.

NOTE

The Align 50 MHz reference feature can only be activated if you have a service password. The password is not available unless the user has purchased the service guide.

Align Current IF Flatness - Activates an immediate measurement of the current IF flatness, for FFT spectral amplitude compensation. Normally this alignment occurs in the background when the instrument bandwidth is changed. Given the current BW and Gain DAC settings for a measurement, alignment is done using the comb calibration signal. The relative amplitude of combs within the BW are compared to expected amplitudes to generate the effective shape of the current IF path.

If Time Corrections are active, this alignment generates complex IF responses (magnitude and phase) rather than just the original scalar (magnitude) response. The complex alignment requires reasonable delay estimation, and improved trigger compensation so the phase response of several averaged measurements can be unwrapped properly.

Align Current SysGain - Activates a fine-tuning adjustment of the system gain. This is done by measuring the response of the current system state configuration to the 50 MHz amplitude reference signal. All subsequent measurements are then compensated appropriately for absolute amplitude accuracy. Normally this occurs in the background when the instrument bandwidth is changed.

- **Corrections** - When set to On (the default state), the alignment firmware applies many numerical corrections to improve amplitude accuracy of the measurement. This includes an absolute amplitude adjustment at center frequency, and IF flatness correction for FFT spans (spectral measurements). When corrections are Off, the background alignments which determine corrections are disabled. Corrections is a background feature which runs automatically, while the instrument is on.
- **Time Corr** - Time corrections are the application of a complex filter directly onto the time capture data. It compensates for the complex (magnitude and phase) response of the analog and digital IF hardware. Time corrections are less efficient (take more CPU cycles) than frequency corrections when only scalar (magnitude) FFT flatness is required, but for demod or other time-based (not FFT) measurements, only time corrections can improve the flatness of imperfect IF hardware. If the time correction functionality is set to Auto (the default), the individual measurements activate the corrections when they are needed.???
- **Restore Align Defaults** - Restores the instrument's align defaults. This feature will only be needed if the instrument calibration locks up, which may occur as a result of hardware problems. Once the defaults are restored a message will appear informing you that alignment is needed.

- **Visible Align** - When toggled to Off, the alignment traces which are visible in the display during an alignment will be turned off, and the alignment process will take less time. When set to High, every alignment trace is shown, resulting in the alignment taking more time than when **Visible Align** is set to Low (the default state), where one out of ten traces is shown. Note that text showing alignment results is displayed on screen when any alignment is activated, even when the visible alignment is set to Off.

Restore Sys Defaults

Press **System**, **More (1 of 3)**, **More (2 of 3)** to access the **Restore Sys Defaults** key. When the **Restore Sys Defaults** key is pressed a **Yes** and a **No** softkey will appear in the **System** softkey menu. Pressing **Yes** will restore system defaults. Note, however, that pressing the **Yes** key will also erase the current IP address, and will set the Host name to **VSA**. The IP address and Host name can be reset by using the IP address and Host name features in the Configuring I/O menu (see [page 62](#)).

Show Errors

Press **System**, **Show Errors** to activate a menu with features that enable you to move around in the error history queue, and to clear the error queue.

Front Panel Key	Level 1	Level 2
System	Show Errors	Top Page
		Last Page
		Next Page
		Prev Page
		Clear Error Queue(s)

- **Clear Error Queue(s)** - The error history queue retains and displays all errors once they have been detected, even if they are no longer detected after a period of time has elapsed. After reviewing the error queue you will likely want to clear it before making another measurement. Note that if an error condition exists continuously, the error will not appear in the queue after the error history queue has been cleared.

You can exit the display of the error history queue to return to a measurement display by pressing either the **ESC** or the **Return** key.

Show System

Press **System**, **More (1 of 3)**, **Show System** to activate a menu with a key that enables you to enter a password, and four information-only keys with a lighter font which show the serial number, model designation, firmware revision, and the host ID.

Front Panel Key	Level 1	Level 2	Level 3
System	More (1 of 3)	Show System	Service Password
			Model
			Serial Number
			Firmware Rev
		Diagnostics	Host ID

NOTE

The diagnostics features, which are accessed through the **Diagnostics** key shown in the table above can only be activated if you have a service password. The password is not available unless the user has purchased the service guide. All descriptions of the service diagnostic features are located in the service guide.

System (Local)

Pressing the **System** front panel key will return the instrument to local control if the instrument was in remote mode being controlled by an external computer.

Using File and Save Keys

The **File** and **Save** keys enable you to save instrument states to memory and to load instrument states into the instrument from memory. For instructions on how to save a screen image to a floppy disc, see [Saving a Screen Image to a Floppy Disc on page 73](#).

Front Panel Key	Level 1	Level 2	Level 3
File	Load State	numeric entry	Enter
File	Save State	numeric entry	Enter
Save	numeric entry	Enter	

Loading a State

1. Press **File, Load State**. A label in the active function area will read `Load State`.
2. Use the numeric keypad to enter the number of the register from which you desire to retrieve a state (you can retrieve states from registers 0 to 19), then press the **Enter** key.

Saving a State

1. Press **File, Save State** or press the front panel **Save** key. An active function labeled `Save State` will appear.
2. Use the numeric keypad to enter the desired state number (you can enter values from 0 to 19), then press the **Enter** key.

Using the Alpha Editor Menu

The alpha editor enables you to enter text. All text entries are displayed in the active function area.

Level 1	Level 2	Level 3	Example
ABCDEFGH	abcdefgh	()::'	V
HIJKLMN	hijklmn	_! ? ~	W
OPQRSTU	opqrstu	+ - * / <> =	X
VWXYZ	vwxyz	^{} []	Y
Done	Done	@ # \$ % ^ &	Z
Space	Space	Space	
More (1 of 3)	More (2 of 3)	More (3 of 3)	

1. You access the alpha editor when you press a key that requires an alpha entry, such as the **Choose Option**, **License Key**, and **Host Name** keys. When the **Choose Option**, **License Key**, or **Host Name** key is pressed, you will see the menu which is shown in level 1 of the table above.
2. If you wish to enter a capital letter, press the key which contains the letter you wish to select. For example, if you want to enter an upper case Y, you will press the **VWXYZ** key. A submenu, as shown in the example column of the table above, is now activated. You will then press the softkey labelled **Y**, and it will appear in the active function area. To access lower case letters press the **More (1 of 3)** key. To access mathematical symbols and punctuation marks press the **More (2 of 3)** key.
3. Press the **Return** front panel key to return to the previous menu without entering characters.
4. To enter a space, press the **Space** key, which is available on both the letters and the symbols **Alpha Editor** menus.
5. If you need to correct a character you have entered, you can use the backspace key to move the cursor in the active function area to the character you need to correct.
6. Once you have completed entering all characters, press the **Done** key.
7. Pressing the **ESC** key at any time prior to pressing the **Done** key will clear the new entry and leave the previous entry unchanged.

Using Printers

Keys in the **Print Setup** menu enable you to select a printer, and to print to a printer or a floppy disk drive.

Front Panel Key	Level 1	Level 2
Print Setup	Print To	File/Printer
	Print Type	gif/xwd
	File Location	Floppy/Internal
	Printer	LaserJet
		DeskJet

Selecting a Type of Printer

1. Press **Print Setup, Printer**.
2. Press the key which has a label that corresponds to the type of printer you are using; the keys available to you are **LaserJet** or **DeskJet**.

How to Print

1. Press the front-panel **Print** key. A copy of the display screen will automatically be sent to the printer or floppy disk according to the parameters set in the **Printer Setup** menu.

How to Save a Screen Image to a Floppy Disc

1. Insert a floppy disc, formatted for MS-DOS, into the front panel disk drive.
2. Press **Printer Setup, Print To**. Toggle the **Print To** key from **Printer** to **File**.
3. Toggle the **File Type** key to select either a gif or an xwd type file.
4. Toggle the **File Location** key to **Floppy**.
5. Press the front panel **Print** key. Once the LED on the disk drive is off remove the disk. The file you have saved, which is an image of the state displayed on the screen, is now available to be printed through use of an external computer and printer, or to be imported into an electronic document.

3 **Setting the Mode**

This chapter explains how to select the mode, and how to modify mode parameters such as input and trigger settings.

Selecting a Mode

The **Mode** menu key is used to select the measurement personality you have purchased with your instrument, or to select the basic or service modes, which are native to the instrument. Upon turn-on the instrument will default to the basic mode.

- **Mode** - Accesses the measurement personality mode. Press the key that corresponds to the option mode you want to select, such as **GSM** or **cdmaOne**. For a full explanation of the personality mode you have purchased, see the documentation which comes with that option.
- **Basic** - This mode is useful for making measurements that are not specified in industry standards, and will be helpful for troubleshooting purposes. Press **Mode**, **Basic** to switch to the basic mode, and bring up the measurements menu. For further explanation of the basic features go to [page 82](#).
- **Service** These features will help you check the functionality of your instrument. Press **Mode**, **Service**, to switch to the service mode, and bring up the service measurements menu. Features accessed through this menu include tests which check the timebase frequency, the sensors on the RF board, and the functionality of the front panel keys. For further explanation of service features go to [page 120](#).

The waveform and spectrum measurements can also be accessed through this menu, as well as a power vs time measurement which is used only for diagnostic purposes. The waveform and spectrum measurements accessed through the service mode are similar to the spectrum and waveform measurements found in the basic mode. However, the measurement setup parameters that you select are only used for the service mode. The basic mode settings remain the same. Explanations of the spectrum and waveform measurements are found in the section on basic features, which starts on [page 91](#).

Note that spectrum and waveform measurements are available in each personality mode, as well as in the basic and service modes.

If you want to set the instrument to a known, factory default state, press **Preset**. This will preset the mode setup and all of the measurements to the factory default parameters. Note that **Preset** does not switch modes.

NOTE

Some features are intended for use only by service personnel and cannot be accessed without a password. If after pressing a key, a message appears requesting entry of a password, this means that the feature is meant for service use only. The password is only available through the service guide.

Mode Setup

When you switch to another mode the instrument automatically presets mode settings to default states for that mode. The settings under mode setup apply to all measurements in the mode.

NOTE

Prior to making measurements, it is important to set the parameters under the mode setup key so they match the device to be tested and your test setup. These parameters are not saved when you switch to another mode. If you want to save these use the save state feature, which is explained on [page 71](#).

The **Mode Setup** key accesses two mode setup menus: (1) the **Input** menu key accesses features including selecting inputs, changing input attenuation, and modifying IF align settings, and (2) the **Trigger** menu key, which enables you to choose trigger setup states for the instrument.

Input Keys

By pressing the **Input** key you access menus which enable you to activate an input port, adjust input attenuation, and adjust the IF align signal.

Activate an Input Port and Adjust Input Power

- **Input Port** key. The **Input Port** menu key accesses a menu which allows you to select one of the following input keys: **RF**, **I/Q**, **I only**, **50 MHz Ref**, and **IF Align**. These keys are explained below.

RF key. Use the **RF** key to reactivate the RF input after a different input has been activated.

I/Q key. Use this input to test I and Q signals which are not modulated onto a carrier.

I only key. Use this input to test I signals which are not modulated onto a carrier.

50 MHz Ref key. Selects the internal 50 MHz reference signal. The displayed signal amplitude will be -25 dBm.

IF Align key. The IF align signal is an internal calibration signal used during the auto align process. You can view this signal and change its characteristics through the IF Align menu.

Adjust Input Attenuation and Input Power.

- **Max Total Pwr** key. The **Max Total Pwr** key can be activated only when **Input Port** is set to **RF**. **Max Total Pwr** allows you to enter maximum power levels (–15 dBm is the default value) for the **RF** input. The maximum total power setting is coupled to the input attenuation setting.
- **I/Q Input Z** key. The **I/Q Input Z** key can be activated only when **Input Port** is set to **I/Q**. The **I/Q Input Z** key enables you to choose an input impedance of either 50 Ω or 600 Ω . An input impedance of 600 Ω may be needed for certain telecommunications applications.
- **Input Atten** key. The **Input Atten** feature can be activated only when **Port** is set to **RF**. The **Input Atten** feature allows you to enter the attenuation value. The input attenuation can be set at values from 0 to 40 dB in increments of 1 dB. The input attenuation setting is coupled to the maximum total power setting.

NOTE

The **Max Total Pwr** and **Input Atten** settings are coupled together. When you switch to a different measurement, the **Max Total Pwr** is kept constant, but the **Input Atten** may change if the two measurements have different mixer margins. Thus, you can directly set the transmitter tester input attenuation, or you can set it indirectly by specifying the maximum expected power at the UUT (**Max Total Pwr** setting).

Adjust the IF Align Signal.

- **Signal Rate** key. To change the rate of the IF align signal you will enter a divider number between 1 to 12. Each divider number increment halves the signal frequency. For example, at the default DAC setting of 1 the signal is set to 234.375 kHz. If the rate is set to 2 the signal is half that frequency, or 117.188 kHz.
- **Signal Amptd** key. To modify the signal amplitude you will enter a DAC value between 0 - 4095. The amplitude range is approximately 50 dB. Incrementing the DAC value increases the amplitude of the signal, and will be visible on screen.
- **Signal Type** key. This menu allows you to select a CW, comb, or pulse type signal as the IF align signal.

Trigger Keys

The **Trigger** key accesses the mode setup menu for the following trigger sources. See [page 79](#) for an explanation of the trigger sources listed below, as well as two additional trigger sources.

- **RF Burst (Wideband)**
- **Video (IF Envp)**
- **Ext Front**
- **Ext Rear**

Pressing one of the trigger source keys will access the mode setup menu. This menu is used to set the **Delay**, **Level**, and **Slope** for each trigger source. Note that the actual trigger source is selected separately for each measurement (under the **Meas Setup** key).

- **Delay** key. This key is used to set the delay time for trigger sources. For trigger delay use positive values. For pre-trigger delay use negative values. The range of the trigger delay is -500 ms to $+500$ ms.
- **Level** key. For the **RF Burst (Wideband)** selection the level is relative to the peak level of the RF signal (for the **RF Burst** trigger you will enter a peak level value with a key labelled **Peak Level**, rather than **Level**). For the **Video** selection the level is the value, in dBm at the RF input, that will cause the trigger. For the **Ext Front** and **Ext Rear** selections, the level range is -5 to $+5$ volts.
- **Slope** key. This key allows you to trigger off of the positive-going edge (**Pos**) or the negative-going edge (**Neg**) of the trigger source signal.

Other keys accessed under the **Trigger** key:

- **Trig Holdoff** key. Sets the period of time before the next trigger can occur.
- **Auto Trig** key. Acts as a trigger timeout. If no trigger occurs by the specified time, a trigger is automatically generated. When set to On the instrument will take data when it receives a signal from the current trigger source; if no signal is received in the expected time period, the time period will default to the Free Run trigger default time period. When set to Off (the default setting) data will only be taken if a trigger has been set, and the Free Run trigger will not be automatically activated.

- **Frame Timer** key. The frame timer feature uses the internal frame clock to generate a trigger signal.
 - **Period** key. Sets the period of the frame clock. Values between 1 ns and 559 ms can be entered.
 - **Offset** key. Allows entry of offset values between 10 ns and 1 s.
 - **Reset Offset** key. Resets the display of the **Offset** key to 0 s.
 - **Sync Source** menu key. See keys listed below.
- **Sync Source** menu key.
 - **Off** key. Deactivates any sync source trigger that has been selected and returns you to the frame timer menu.
 - **Ext Front** key. Synchronizes the measurement to an external sync source, such as a frame clock signal. The starting point is the point coinciding with the external trigger point plus the external trigger delay.
 - **Ext Rear** key. Synchronizes the measurement to an external sync source, such as a frame clock signal. The starting point is the point coinciding with the external trigger point plus the external trigger delay.
 - **RF Burst** key. Synchronizes the measurement to the internal, wideband RF burst trigger.

Selecting the Frequency/Channel

Use the **FREQUENCY/Channel** front panel key to set the center frequency or select the channel for the measurement you want to make.

Basic Measurements

Basic measurements are useful for making measurements that are not specified in measurement standards, and will be useful if you need to troubleshoot a measurement operation. In addition, having spectrum and waveform measurements available independently of personality modes provides extra flexibility.

To access the Basic mode press the **Mode** key and select the **Basic** softkey. The following measurements are then available by pressing the **Measure** key:

Spectrum on [page 91](#)

Waveform on [page 99](#)

Channel Power on [page 106](#)

Adjacent Channel Power on [page 111](#)

When you press the key to select the measurement it will become the active measurement, using settings and a display unique to that measurement. Data acquisitions will automatically begin provided trigger requirements, if any, are met.

Preparing for Measurements

If you want to set the Basic mode to a known, factory default state, press **Preset**. This will preset the mode setup and all of the measurements to the factory default parameters.

NOTE

Pressing the **Preset** key does not switch instrument modes.

To preset only the settings that are specific to a specific measurement, select the measurement and press **Meas Setup, More, Restore Meas Defaults**. This will set the measure setup parameters to the factory defaults for the currently selected measurement only.

Initial Setup

Before making a measurement, make sure the mode setup and frequency/channel parameters are set to the desired settings. Refer to the sections [“Mode Setup”](#) and [“Selecting the Frequency/Channel”](#) in the previous chapter.

How to Make a Measurement

The following table summarizes the steps you will follow in making a measurement:

Step	Primary Key	Setup Keys	Related Keys
1. Select & setup a mode	Mode	Mode Setup, Input, Frequency Channel	System
2. Select & setup a measurement	Measure	Meas Setup	Meas Control, Restart
3. Select & setup view	View/Trace	Span X Scale, Amplitude Y Scale, Display, Next Window, Zoom	File, Save, Print, Print Setup, Marker, Search

Using Measure Keys

The **MEASURE** front panel key allows you to activate one measurement from those available in the current mode. The measurements that are available will vary depending on which mode you have selected. It may be a measurement personality mode, the basic mode, or the service mode.

Measurement Control

Following your selection of the instrument mode and mode setup you will use keys in the **Meas Control** keys to control processes that affect the running of the current measurement.

- **Measure** - Toggles between Single and Cont (for continuous) measurement states. When set to Single the measurement will continue until it has reached the specified number of averages set by the average counter. When set to Cont the measurement will run continuously, and perform averaging according to the current average type (repeat or exponential). The default is continuous. See [page 85](#) for an explanation of averaging.
- **Pause** - Pauses the current measurement. Once toggled, the label of the **Pause** key changes to read **Resume**. The **Resume** key continues the active measurement from the point at which it was paused.

The **Restart** key repeats the current measurement from the beginning, while retaining the current measurement settings.

Measurement Setup

The **Meas Setup** key accesses features that enable you to adjust parameters of the current measurement, such as resolution bandwidth. You will also use the **Meas Setup** menu to access **Average**, **Trig Source**, and **Advanced** measure setup feature menus.

The following measure setup features can be used with many measurements:

- **Res BW** - Changes the resolution bandwidth of a given measurement. Selection of a narrower bandwidth will result in a longer data acquisition time.
- **Restore Meas Defaults** - Presets only the settings that are specific to the selected measurement. This will set the measure setup parameters to the factory defaults, only for the currently selected measurement.

Averaging

Features in the **Average** menu allow you to modify the number, average mode, and type of averaging you use for the currently selected measurement. The features available for averaging will vary slightly depending on the measurement that is currently active. On the display averaged trace results are shown in blue, while the instantaneous signal is shown in yellow.

- **Avg Number** - Modifies the number of times the current measurement will be repeated with the results from the repeated measurements averaged. Increased averages usually give more accurate results. There will be an increase in the time taken to make a measurement if the number of averages is increased.
- **Avg Mode** - Selects between an **Exp** (exponential) or a **Repeat** mode of averaging. This selection only affects the averaging after the number of N averages is reached (set using **Avg Number**). Normal (linear) averaging is always used until the specified number of N averages is reached. When **Measure** is set to Single, data acquisitions are stopped when the number of averages is reached. Therefore **Avg Mode** has no effect on single measurements.

Exponential averaging: When **Measure** is set at Cont (continuous) data acquisitions will continue indefinitely. After N averages, exponential averaging is used with a weighting factor of N (the displayed average count stops at N). Exponential averaging weights new data more than old data, which facilitates tracking of slow-changing signals. The value of N is set through use of the **Average** key or the **Avg Bursts** key.

Repeat averaging: When **Measure** is set at Cont, data acquisitions will continue indefinitely. After N averages is reached, all previous result data is cleared and the average count is set back to 1. This is equivalent to pressing **Measure, Single** and then pressing the **Restart** key each time the single measurement finishes.

- **Avg Type** - Allows you to select type of averaging. Only the types of averaging that are appropriate for the current measurement are available in that measurement. The following average types are available:

Pwr Avg - Averages the power, which is equivalent to the rms of the voltage. This is the default type of averaging.

Log-Pwr Avg - The log of the power is averaged. This is also known as video averaging.

Voltage Avg - The voltage is averaged.

Maximum - The maximum values are retained.

Minimum - The minimum values are retained.

Trigger Source

Changing the **Trig Source** alters the trigger source for the current measurement only. Not all of the selections are available for all measurements. Note that the **RF Burst**, **Video**, **Ext Front**, and **Ext Rear** menu keys found in the **Trigger** menu enable you to change settings to modify the delay, level, and slope for each of these trigger sources (as described on [page 79](#)). Choose one of the following trigger sources:

- **Free Run** - Triggers at the time the data is requested, completely asynchronous to the RF or IF signals.
- **Video** - Is an internal IF envelope trigger. It triggers on an absolute threshold level of the signal passed by the IF.
- **RF Burst** - Is an internal wideband RF burst trigger that has an automatic level control for burst signals.
- **Ext Front** - Activates the front panel **Ext Trigger Input**. The external trigger must be a signal between -5 and +5 volts.
- **Ext Rear** - Activates the rear panel **Trigger In**. The external trigger must be a signal between -5 and +5 volts.
- **Frame** - Uses the internal frame clock to generate a trigger signal. The clock parameters are controlled under the **Mode Setup** key or the measurement firmware, not both. See the specific measurement for details.
- **Line** - Activates an internal line trigger. Sweep triggers occur at intervals synchronized to the line frequency.

Rear panel **TRIGGER 1 OUT** and **TRIGGER 2 OUT** connectors are coupled to the selected trigger source. These trigger outputs are always on the rising edge with a pulse width of at least 1 μ s.

Changing the View

The following keys enable you to select the desired view of the measurement and to change scale parameters for the graphic window.

View/Trace - Selects a predefined view of the current measurement and highlights the selected window. Once a window is selected, the X and Y scale keys can be used to modify scale parameters. The types of windows, and X and Y scale parameters that are available will vary, depending on the measurement you have activated.

- **Typical Measurement Windows**

Spectrum window - Select this window if you want to view a signal in parameters of frequency and power. Changes to frequency span or power will sometimes affect data acquisition. For more details see the section on spectrum measurements.

RF Envelope window - Select this window to view a signal in parameters of time and power. For more detail see the section on waveform measurements.

I/Q Waveform window - Select this window to view the I and Q signal characteristics of the current measurement in parameters of voltage and time. This window is in both the spectrum and waveform measurements.

Press **View/Trace, Spectrum**, to view a spectrum measurement window, or **View/Trace, Waveform** to view a waveform measurement window.

- **Trace Display**

All - Displays both the current and the average trace.

Average - Displays only the average trace. The average trace is shown in blue.

Current - Displays only the trace for the latest data acquisition. The current trace is shown in yellow.

- **Span / X Scale Keys**

Span key. This key allows you to modify the frequency span. Changes in span may affect data acquisition.

Scale/Div key. This key allows you to modify the X scale parameter in units of time.

Sweep Time key. This key allows you to modify sweep time. Changes in sweep time will affect data acquisition.

Ref Value key. This key allows you to set the value of the reference level for X scale display in units of time.

Ref Position key. This key allows you to place the current reference level on the left, the center, or the right of the display. This is used for X scale display either in units of frequency or time.

Scale/Coupling key. This key couples the scale/division to the sweep time for measurements made in the time domain.

- **Amplitude / Y Scale Keys**

Scale/Div key. This key enables you to set the dB/Division (for the Spectrum and the RF Envelope windows) or V/Division (for the I/Q window).

Ref Value key. This key allows you to set the value of the reference, in units of dB (for the RF Envelope window), or in units of mV (for the I/Q window).

Ref Position key. This key allows you to move the current reference level to the top, center, or bottom of the display.

Using Markers

Markers enable you to make measurements on screen. Keys in the **Marker** menu control the number and types of markers you can access. **Trace** keys allow you to select the trace on which you will activate a marker. The **Search** key enables you to perform an immediate peak search and activate a marker at the peak signal.

Paths to access any of the features listed below will be found next to the specific key listed in the key access table which begins on [page 53](#)

Trace

The **Trace** keys allow you to select the trace that will be used for the other marker keys. You can then use marker features to obtain the results you desire. To access **Trace** keys press **Marker, Trace**.

NOTE

The selections in the **Trace** menu include traces on all windows for the current measurement, including windows that are not currently displayed.

When making waveform measurements you can activate the following trace keys: **RF Envelope** and **I/Q Waveform** keys.

When making spectrum measurements you can activate: **Spectrum**, **Spectrum Avg**, and **I/Q Waveform** keys. The spectrum average trace feature places a marker on the average trace in the spectrum window.

Markers

Up to four markers can appear on the display simultaneously but only one marker can be activated and moved at a time. This marker is called the “active” marker. Press **Marker** to access the keys below, except for the **Shape** and **Marker All Off** keys, which require you to press **Marker, More (1 of 2)**.

- **Normal** - Activates a single marker on the selected trace (as set by the trace key) in units either of frequency or time, depending on the measurement mode that is currently active. However, if a marker has previously been activated, that marker will persist as the default marker until it is changed. You can change the position of the marker through use of the front panel step keys and RPG knob. Annotation in the active function area and the upper right hand corner of the display indicate the value of the active marker in units of the window which contains that marker. Pressing **Normal** also deactivates any marker delta functions which have been activated previously.

- **Select** - Enables you to select one, or more, of the four available markers. Once selected, a marker can be activated, or deactivated, by using the **Normal**, **Delta**, or **Function** keys. If a marker has previously been turned on and assigned to a specific trace it will become active on that trace when the **Select** key is pressed.
- **Delta** - Places two markers on the selected trace or, if a marker is already active, places a second marker at the position of the active marker. You can activate up to two sets of delta markers. Annotation in the active function area and in the upper-right corner of the display show differences between the two markers in the units of the window which contains that marker.
- **Off** - Turns off the selected marker (as set by the **Select** key).
- **Marker All Off** - Turns off all markers.
- **Shape** - Allows you to select markers in the shapes of diamonds, crosses, squares, and lines. The line markers run vertically, from the bottom to the top of the display, while the diamond, square, and cross shapes simply allow you to distinguish different points on the trace by using different shapes. You may use up to four different shaped markers at a given time, although only one may be active.

Marker Functions

The marker **Function** menu key enables you to use two marker functions: **Band Power** and **Noise**. These functions do not apply to all measurements; if you attempt to press a function key for a function that is not applicable to that measurement a message will appear telling you that the function is not supported under the current measurement. These functions are described below. Press **Marker, Function** to access the following keys.

- **Band Power** - Allows you to place two markers to either side of a band so you can measure the power within that band. You can use the **RPG** knob to move the band markers; the numerical power reading will be visible in the upper right corner of the display. This feature is particularly useful for measuring channel power.
- **Noise** - Normalizes the equivalent amplitude of the measured noise to a 1 Hz bandwidth, which is centered around the displayed marker. This is done by sampling and displaying the average of 32 data points.

Search Marker

The front panel **Search** key performs a peak search when pressed. A marker will automatically be activated at the highest peak.

Making the Spectrum (Frequency Domain) Measurement

Purpose

The spectrum measurement provides spectrum analysis capability for the instrument. The control of the measurement was designed to be familiar to those who are accustomed to using swept spectrum analyzers.

This measurement is FFT (Fast Fourier Transform) based. The FFT-specific parameters are located in the **Advanced** menu. Also available under basic mode spectrum measurements is an I/Q window, which shows the I and Q signals in parameters of voltage and time. The advantage of having an I/Q view available while in the spectrum measurement is that it allows you to view complex components of the same signal without changing settings or measurements.

Measurement Method

The transmitter tester uses digital signal processing to sample the input signal and convert it to the frequency domain. With the instrument tuned to a fixed center frequency, samples are digitized at a high rate, converted to I and Q components with DSP hardware, and then converted to the frequency domain with FFT software.

Making the Measurement

NOTE

The factory default parameters provide a good starting point. You will likely want to change some of the settings. Press **Meas Setup, More (1 of 2), Restore Meas Defaults** at any time to return all parameters for the current measurement to their default settings.

Press **Measure, Spectrum (Freq Domain)** to immediately make Spectrum (Frequency Domain) the active measurement.

To change any of the measurement parameters from the factory default values, refer to the “Changing the Measurement Setup” section for this measurement.

Results

A display with both a spectrum window and an I/Q Waveform window will appear when you activate a spectrum measurement. Use the **Next Window** key to select a window, and the **Zoom** key to enlarge a window.

Figure 1 Spectrum Measurement Result- Spectrum Window

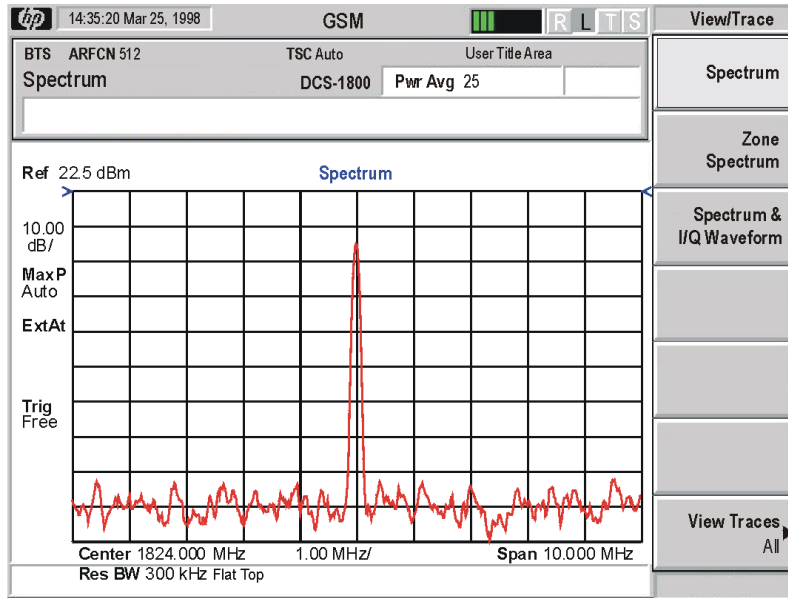

pa85a

Figure 2 Spectrum Measurement Result- I/Q Waveform Window

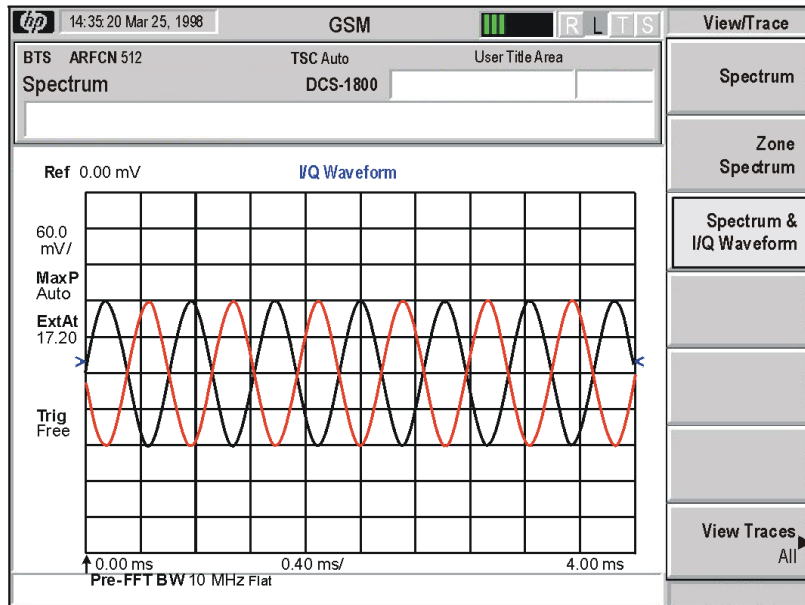

pa84a

Changing the Measurement Setup

Table 1 Spectrum (Frequency Domain) Measurement Defaults

Measurement Parameter	Factory Default Condition
Res BW	20.0000 kHz (Auto)
Averaging:	
Avg Number	25 On
Avg Mode	Exp
Avg Type	Log-Pwr Avg (Video)
Trigger Source	Free Run (Immediate)
Measurement Time (Service mode only)	1.0 ms (Auto)
Spectrum Window:	
Span	1.00000 MHz
Scale/Div - Amplitude Y Scale	10.00 dB
I/Q Waveform Window:	
Capture Time	188.00 μ s
Scale/Div - Amplitude Y Scale	60 mV
Advanced	
Pre-ADC BPF	On
Pre-FFT Filter	Flat
Pre-FFT BW	1.55000 MHz (Auto)
FFT Window	Flat Top (High AmptdAcc)
FFT Size:	
Length Control	Auto
Min Points/RBW	1.300000
Window Length	706
FFT Length	4096
ADC Range	Auto Peak
Data Packing	Auto
ADC Dither	Auto
Decimation	0 (Auto)
IF Flatness	On

NOTE Parameters under the **Advanced** key seldom need to be changed. Any changes from the default advanced values may result in invalid measurement data.

Make sure the **Spectrum (Freq Domain)** measurement is selected under the **Measure** menu. Press the **Meas Setup** key to access a menu which allows you to modify the averaging, and trigger source for this measurement (as described in the “Measurement Setup” section). In addition, the following parameters can be modified:

- **Span** - This key allows you to modify the frequency span. Changing the span causes the bandwidth to change automatically, and will affect data acquisition time.
- **Res BW** - This feature sets the resolution bandwidth for the FFT, and allows manual or automatic settings. A narrower bandwidth will result in a longer data acquisition time. In Auto mode the resolution bandwidth is set to Span/50 (2% of the span).
- **Advanced** - The following FFT advanced features should be used only if you are familiar with their operation. Changes from the default values may result in invalid data.

Pre-ADC BPF - This key allows you to toggle the pre-ADC bandpass filter to On or Off states. The pre-ADC bandpass filter is useful for rejecting nearby signals, so that sensitivity within the span range can be improved by increasing the ADC range gain.

Pre-FFT Fltr - Allows you to toggle between **Flat** (flat top) and **Gaussian**. The pre-FFT filter defaults to a flat top filter which has better amplitude accuracy. The Gaussian filter has better pulse response.

Pre-FFT BW - The Pre-FFT bandwidth allows you to select between a manual or an automatic setting. The pre FFT-bandwidth filter can be set between 1 Hz and 10 MHz. In Auto mode this bandwidth is nominally 50% wider than the span. This bandwidth determines the ADC sampling rate.

FFT Window - Allows you to access the following selection menu. Unless you are familiar with FFT windows, use the flat top filter (the default filter).

- **Flat Top** - Selects a filter for best amplitude accuracy, by reducing scalloping error.
- **Uniform** - You can select to have no window active by using the uniform setting.
- **Hanning**
- **Hamming**
- **Gaussian** - Selects a gaussian filter with an alpha of 3.5.
- **Blackman**
- **Blackman Harris**
- **K-B 70dB / 90dB/ 110dB (Kaiser-Bessel)** - Allows selection of Kaiser-Bessel filters with sidelobes of -70 , -90 , or -110 dBc.

FFT Size - This menu contains the following features:

- **Length Ctrl** - This feature allows you to set the FFT and window lengths either automatically or manually.
- **Min Pts in RBW** - This feature allows you to set the minimum number of data points that will be used inside the resolution bandwidth. This adjustment is only available if the **Length Ctrl** key is set to Auto.
- **Window Length** - This feature allows you to enter the FFT window length ranging from 8 to 1048576. This length represents the actual quantity of I/Q samples that are captured for processing by the FFT. This value can only be entered if length control is set to Manual.
- **FFT Length** - This feature allows you to enter the FFT length in the number of captured samples, ranging from 4096 to 1048576. The FFT length setting is automatically limited so that it is equal or greater than the FFT window length setting. Any amount greater than the window length is implemented by zero-padding. This value can be entered only if length control is set to Man (manual).

ADC Range - Allows you to access the following selection menu to define one of the following ADC ranging functions:

- **Auto** - Select this to set the ADC range automatically. For most FFT spectrum measurements, the auto feature should not be selected. An exception is when measuring a signal which is “bursty”, in which case auto can maximize the time domain dynamic range, if FFT results are less important to you than time domain results.
- **Auto Peak** - Select this to set the ADC range automatically to the peak signal level. Auto peak is a compromise that works well for both CW and burst signals.

- **AutoPeakLock** - Select this to hold the ADC range automatically at the peak signal level. Auto peak lock is more stable than auto peak for CW signals, but should not be used for “bursty” signals.
- **Manual** - Allows you to access the selection menu: **-6 dB, 0 dB, +6 dB, +12 dB, +18 dB, +24 dB**, to set the ADC range level. Also note that manual ranging is best for CW signals.

Data Packing - Allows you to access the following selection menu to define one of the following data packing methods:

- **Auto** - Data is automatically packed. This is the default setting and most recommended.
- **Short (16 bit)** - Data is packed by every 16 bits.
- **Medium (24 bit)** - Data is packed by every 24 bits.
- **Long (32 bit)** - Data is packed by every 32 bits.

ADC Dither - Allows you to toggle the ADC dither function between **Auto, On, and Off**. When set to auto (the default), ADC dither will be activated when a narrow bandwidth is being measured, and deactivated when a wide bandwidth is being measured. “ADC dither” refers to the introduction of noise to the digitized steps of the analog-to-digital converter; the result is an improvement in amplitude accuracy. Use of the ADC dither, however, reduces dynamic range by approximately 3 dB.

Decimation - Allows you to toggle the decimation function between **Auto** and **Man**, and to set the decimation value. **Auto** is the preferred setting, and the only setting that guarantees alias-free FFT spectrum measurements. If you are familiar with the decimation feature, you can change the decimation value by setting to **Man**, but be aware that aliasing can result in higher values.

IF Flatness - Allows you to toggle between **On** and **Off**. When toggled to **On** (the default), the IF flatness feature causes background amplitude corrections to be performed on the FFT spectrum. The **Off** setting is used for adjustment and troubleshooting the transmitter tester.

Changing the View

View/Trace menu keys are used to activate a view of a measurement with preset X and Y scale parameters, called a “window”. Using the X and Y Scale keys you can then modify these parameter settings. You can also activate specific traces, using the **Trace Display** menu key.

Windows Available for Spectrum Measurements

The spectrum and the I/Q windows can be viewed at the same time, or individually. You can use the **Next Window** and **Zoom** keys to move between these different views.

Spectrum window Select this window if you want to view frequency and power. Changes to frequency span or power will sometimes affect data acquisition.

I/Q Waveform window. Select this window to view the I and Q signal characteristics of the current measurement in parameters of voltage and time.

NOTE

For the widest spans the I/Q window becomes just “ADC time domain samples”, because the I/Q down-conversion is no longer in effect.

Using the Markers

The **Marker** front-panel key accesses the menu to configure the markers. If you want to use the marker function in the I/Q window, press **View/Trace, I/Q Waveform, Marker, Trace, IQ Waveform**.

- **Select 1 2 3 4** - Allows you to activate up to four markers with the corresponding numbers, respectively. The selected number is underlined and its function is defined by pressing the **Function** key. The default is 1.
- **Normal** - Allows you to activate the selected marker to read the frequency and amplitude of the marker position on the spectrum trace, for example, which is controlled by the **RPG** knob.
- **Delta** - Allows you to read the differences in frequencies and amplitudes between the selected marker and the next.
- **Function Off** - Allows you to define the selected marker function to be **Band Power**, **Noise**, or **Off**. The default is **Off**. If set to **Band Power**, you need to select **Delta**.
- **Trace Spectrum** - Allows you to place the selected marker on the **Spectrum**, **Spectrum Avg**, or **I/Q Waveform** trace. The default is **Spectrum**.
- **Off** - Allows you to turn off the selected marker.

- **Shape Diamond** - Allows you to access the menu to define the selected marker shape to be a **Diamond**, **Line**, **Square**, or **Cross**. The default is a **Diamond**.
- **Marker All Off** - Allows you to turn off all of the markers.

The front panel **Search** key performs a peak search when pressed. A marker will automatically be activated at the highest peak.

Band Power

A band power measurement using the markers calculates the average power between two adjustable markers. To make a band power measurement:

Press the **Marker** key.

Press **Trace**, **Spectrum** to activate a marker on the instantaneous spectrum signal. Press the **Spectrum Avg** key to activate a marker on the average spectrum trace.

Press **Function**, **Band Power**.

Two marker lines are activated at the extreme left side of the horizontal scale. Press **Normal** and move marker 1 to the desired place by rotating the **RPG** knob.

Press **Delta** to bring marker 2 to the same place as marker 1.

Move marker 1 to the other desired position by rotating the **RPG** knob. Band power measures the average power between the two markers. When the band power markers are active, the results are shown in the results window as Mean Pwr (Between Mks). When the band power function is off the results window reads Mean Pwr (Entire Trace).

Troubleshooting Hints

Changes made by the user to advanced spectrum settings, particularly to ADC range settings, can inadvertently result in spectrum measurements that are invalid and cause error messages to appear. Care needs to be taken when using advanced features.

Making the Waveform (Time Domain) Measurement

Purpose

The waveform measurement is a generic measurement for viewing waveforms in the time domain. This measurement is how the instrument performs the zero span functionality found in traditional spectrum analyzers. Also available under basic mode waveform measurements is an I/Q window, which shows the I and Q signal in parameters of voltage and time. The advantage of having an I/Q view available while in the waveform measurement is that it allows you to view complex components of the same signal without changing settings or measurements.

The waveform measurement can be used to perform general purpose power measurements to a high degree of accuracy.

Measurement Method

The transmitter tester makes repeated power measurements at a set frequency, similar to the way a swept-tuned spectrum analyzer makes zero span measurements. The input analog signal is converted to a digital signal, which then is processed into a representation of a waveform measurement. The transmitter tester relies on a high rates of sampling to create an accurate representation of a time domain signal.

Making the Measurement

NOTE

The factory default parameters provide a good starting point. You will likely want to change some of the settings. Press **Meas Setup, More (1 of 2), Restore Meas Defaults** at any time to return all parameters for the current measurement to their default settings.

Press **Measure, Waveform (Time Domain)** to immediately make Waveform (Time Domain) the active measurement.

To change any of the measurement parameters from the factory default values, refer to the “Changing the Measurement Setup” section for this measurement.

Results

Figure 3 Waveform Measurement Results- RF Envelope Window

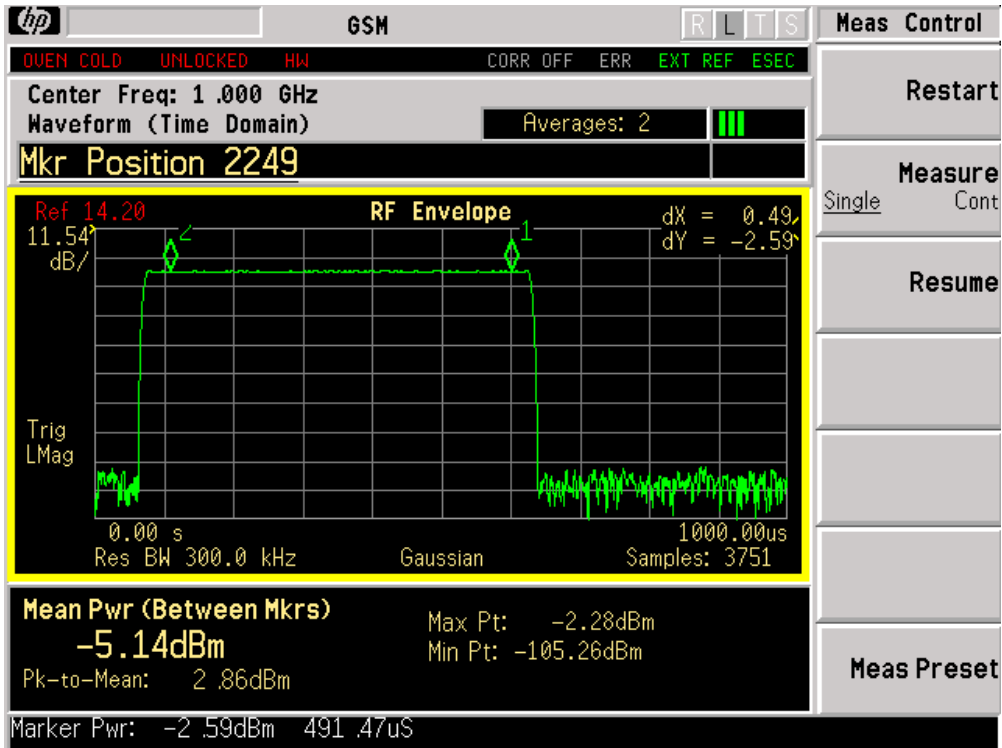
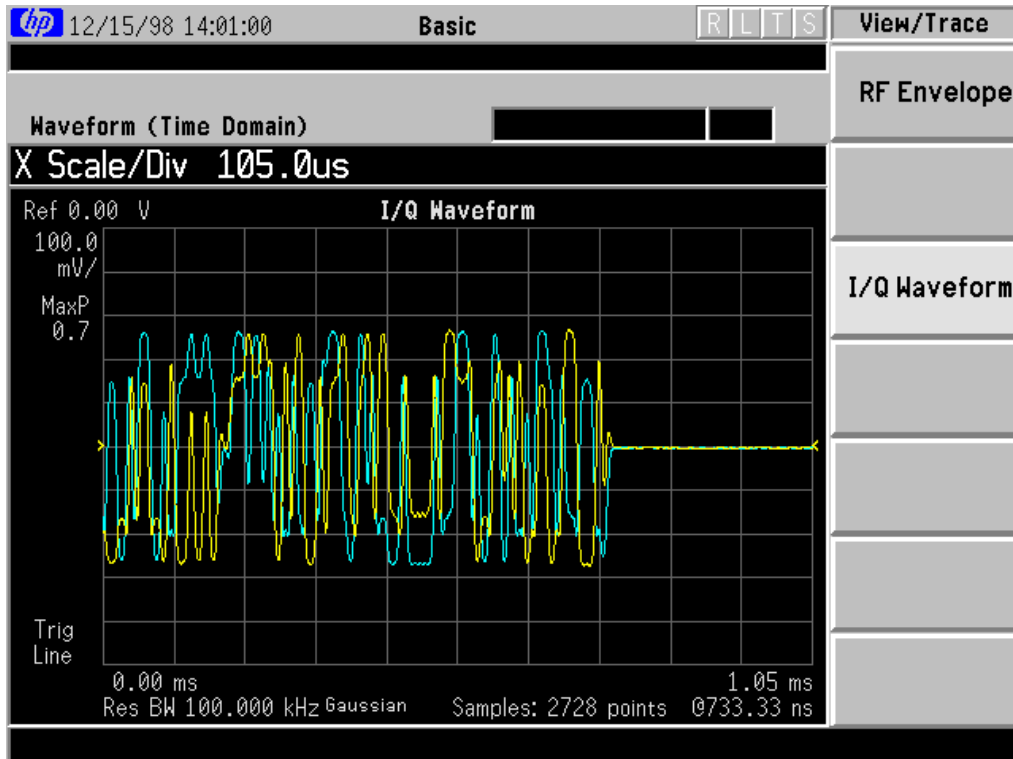

Figure 4 Waveform Measurement Results - I/Q Waveform Window



Changing the Measurement Setup

Table 2 Waveform (Time Domain) Measurement Defaults

Measurement Parameter	Factory Default Condition
View/Trace	RF Envelope
Sweep Time	2.000 ms
Res BW	100.000 kHz
Averaging:	
Avg Number	10 Off
Avg Mode	Exp
Avg Type	Pwr Avg (RMS)
Trigger Source	Free Run (Immediate)
RF Envelope Window:	
Amplitude Y Scale	
Scale/Div	10.00 dB
Reference	0.00 dBm (Top)
I/Q Waveform Window:	
Amplitude Y Scale	
Scale/Div	100.0 mv
Reference	0.00 V (Ctr)
Advanced	
Pre-ADC BPF	Off
RBW Filter	Gaussian
ADC Range	Auto
Data Packing	Auto
ADC Dither	Off
Decimation	Off

NOTE Parameters that are under the **Advanced** key seldom need to be changed. Any changes from the default values may result in invalid measurement data.

Make sure the **Waveform (Time Domain)** measurement is selected under the **Measure** menu. Press the **Meas Setup** key to access a menu which allows you to modify the averaging, and trigger source for this measurement (as described in the “Measurement Setup” section). In addition, the following parameters can be modified:

- **Sweep Time** - This key allows you to select the measurement acquisition time. It is used to specify the length of the time capture record. Values between 10 μ s and 50 s can be entered, depending upon the resolution bandwidth setting.
- **Res BW** - This key sets the measurement bandwidth. A larger bandwidth results in a larger number of acquisition points and reduces the maximum allowed for sweep time. You can enter values between 10 Hz. and 7.5 MHz.
- **Advanced menu key**. This key accesses the features listed below.

Pre-ADC BPF - This key allows you to toggle the pre-ADC bandpass filter to On or Off states. The pre-ADC bandpass filter is useful for rejecting nearby signals, so that sensitivity within the span range can be improved by increasing the ADC range gain

RBW Filter - This key toggles to select a flat top or a Gaussian resolution bandwidth filter. A Gaussian filter provides more even time domain response, particularly for bursts. A flat top filter provides a flatter bandwidth but is less accurate for pulse responses. A flat top filter also requires less memory and allows longer data acquisition times. For most waveform applications, the Gaussian filter is recommended, and it is the default filter for waveform measurements.

ADC Range -.Allows you to access the following selection menu to define one of the following ADC ranging functions:

- **Auto** - This key causes the instrument to automatically adjust the signal range for optimal measurement results.
- **AutoPeak** - This key causes the instrument to continuously seek the highest peak signal.
- **AutoPeakLock** - This key causes the instrument to adjust the range for the highest peak signal it identifies, and retains the range settings determined by that peak signal, even when the peak signal is no longer present.
- **Manual** - Allows you to access the selection menu: **-6 dB, 0 dB, +6 dB, +12 dB, +18 dB, +24 dB**, to set the ADC range level. Also note that manual ranging is best for CW signals.

Data Packing - Allows you to access the following selection menu to define one of the following data packing methods:

- **Auto** - Data is automatically packed. This is the default setting and most recommended.
- **Short (16 bit)** - Data is packed by every 16 bits.
- **Medium (24 bit)** - Data is packed by every 24 bits.
- **Long (32 bit)** - Data is packed by every 32 bits.

ADC Dither - Allows you to toggle the ADC dither function between **On** and **Off**. Activation of the ADC dither results in better amplitude linearity and resolution in low level signals. However, it also results in reduced dynamic range. ADC dither is set to **Off** by default.

Decimation - Allows you to toggle the decimation function between **On** and **Off** and to set the decimation value. Decimation allows longer acquisition times for a given bandwidth by eliminating data points. Long time captures can be limited by the transmitter tester data acquisition memory. Decimation numbers 1 to 4 describe the factor by which the number of points are reduced. A decimation figure of 1, which results in no data point reduction, is the default.

Changing the View

The **View/Trace** menu keys are used to activate a view of a measurement with preset X and Y scale parameters; this view is called a “window.” Using the X and Y scale keys, you can then modify these parameters. You can also activate traces, using the **Traces Display** menu key.

Windows Available for Waveform Measurements

RF Envelope window. Select this window if you want to view power (in dBm) vs. time. Remember that data acquisition will be affected when you change the sweep time.

I/Q Waveform window. Select this window to view the I and Q signal characteristics of the current measurement in parameters of voltage and time.

Using the Markers

The **Marker** front-panel key accesses the menu to configure the markers. If you want to use the marker function in the I/Q window, press **View/Trace, I/Q Waveform, Marker, Trace, IQ Waveform**.

- **Select 1 2 3 4** - Allows you to activate up to four markers with the corresponding numbers, respectively. The selected number is underlined and its function is defined by pressing the **Function** key. The default is 1.
- **Normal** - Allows you to activate the selected marker to read the frequency and amplitude of the marker position on the spectrum trace, for example, which is controlled by the **RPG** knob.
- **Delta** - Allows you to read the differences in frequencies and amplitudes between the selected marker and the next.
- **Function Off** - Allows you to define the selected marker function to be **Band Power, Noise, or Off**. The default is **Off**. If set to **Band Power**, you need to select **Delta**.
- **Trace Spectrum** - Allows you to place the selected marker on the **Spectrum, Spectrum Avg, or I/Q Waveform** trace. The default is **Spectrum**.
- **Off** - Allows you to turn off the selected marker.
- **Shape Diamond** - Allows you to access the menu to define the selected marker shape to be a **Diamond, Line, Square, or Cross**. The default is a **Diamond**.
- **Marker All Off** - Allows you to turn off all of the markers.

The front panel **Search** key performs a peak search when pressed. A marker will automatically be activated at the highest peak.

NOTE

In the Waveform measurement, the Mean Pwr (Entire Trace) value plus the Pk-to-Mean value will sum to equal the current Max Pt. value as shown in the data window below the RF Envelope display. If you do a marker peak search (**Search**) with averaging turned off, the marker will find the same maximum point. However, if you turn averaging on, the Pk-to-Mean value will use the highest peak found for any acquisition during averaging, while the marker peak will look for the peak of the display, which is the result of n-averages. This will usually result in differing values for the maximum point.

Band Power

A band power measurement using the markers calculates the average power between two adjustable markers. To make a band power measurement:

Press the **Marker** key.

Press **Function, Band Power**.

Two marker lines are activated at the extreme left side of the horizontal scale. Press **Normal** and move marker 1 to the desired place by rotating the **RPG** knob.

Press **Delta** to bring marker 2 to the same place as marker 1.

Move marker 1 to the other desired position by rotating the **RPG** knob. Band power measures the average power between the two markers. When the band power markers are active, the results are shown in the results window as Mean Pwr (Between Mks). When the band power function is off the results window reads Mean Pwr (Entire Trace).

Troubleshooting Hints

Changes made by the user to advanced waveform settings can inadvertently result in measurements that are invalid and cause error messages to appear. Care needs to be taken when using advanced features.

Making the Channel Power Measurement

Purpose

The Channel Power measurement is a common test used in the wireless industry to measure the total transmitted power of a radio within a defined frequency channel. This procedure measures the total power within the defined channel. This measurement is applied to design, characterize, evaluate, and verify transmitters and its components or devices for base stations and mobile stations.

Measurement Method

The Channel Power measurement reports the total power within the channel bandwidth. The transmitter tester acquires a number of points representing the input signal in the time domain. It transforms this information into the frequency domain using FFT and then calculates the channel power. The effective resolution bandwidth of the frequency domain trace is proportional to the number of points acquired for FFT. The fastest FFT process is achieved using a number of acquired points that is a power of 2 (for example: 64, 128, 512). Since the measurement is optimized for speed and accuracy, you are permitted to change only the number of acquired data points in powers of 2, not the actual resolution bandwidth. However, if absolute sweep time is required, sweep time can be changed to the user's specified time at the expense of reduced speed. At no time will both sweep time and data points be set to manual because of conflicting parameter settings. This flexibility is available through the **Advanced** menu of the channel power measurement.

To improve repeatability, you can increase either the number of averages or the number of data points with longer time record length. The channel power graph is shown in the graph window and the absolute channel power in dBm and the mean power spectral density in dBm/Hz are shown in the text window.

Making the Measurement

NOTE

The factory default settings provide a good starting point. You will likely want to change some of the settings. Press **Meas Setup, More (1 of 2), Restore Meas Defaults** at any time to return all parameters for the current measurement to their default settings.

Select the desired center frequency.

Press **Measure, Channel Power** to immediately make Channel Power the active measurement.

To change any of the measurement parameters from the factory default values, refer to the “Changing the Measurement Setup” section.

Results

The following figure shows an example result of channel power measurements. The channel power graph is shown in the graph window. The absolute channel power and its mean power spectral density are shown in the text window.

Figure 4-1 Channel Power Measurement

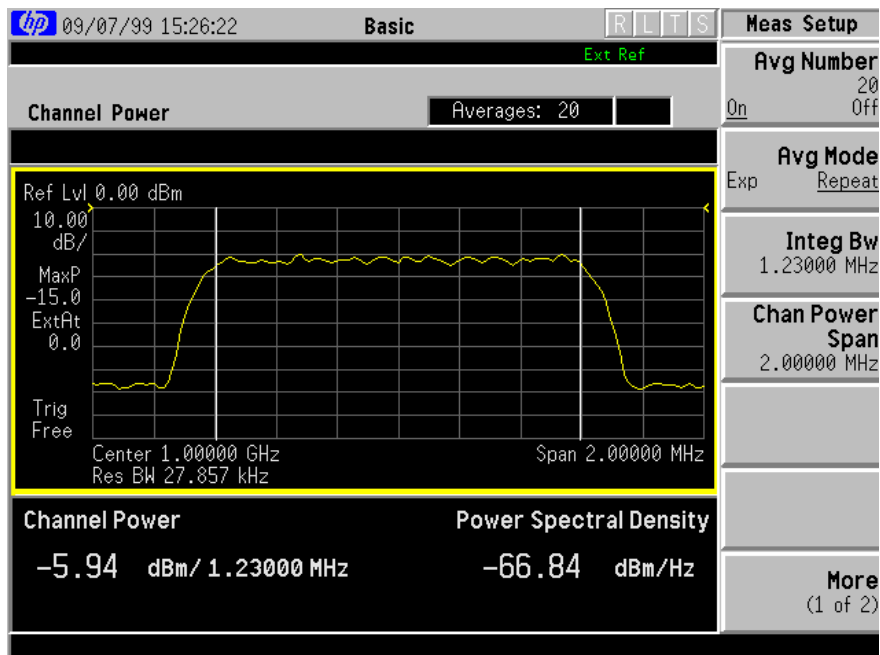

Changing the Measurement Setup

The next table shows the factory default settings for channel power measurements.

Table 4-1 Channel Power Measurement Defaults

Measurement Parameter	Factory Default Condition
Meas Setup:	
Avg Number	20 On
Avg Mode	Repeat
Integ BW	1.23000 MHz
Chan Power Span	2.00000 MHz
Advanced	
Sweep Time	68.27 μ s Auto
Data Points	512 Auto
Trig Source	Free Run (Immediate)

NOTE

Parameters under the **Advanced** key seldom need to be changed. Any changes from the factory default values may result in invalid measurement data.

Make sure the **Channel Power** measurement is selected under the **Measure** menu. The **Meas Setup** key accesses the menu which allows you to modify the average number and average mode for this measurement.

The following parameters can be changed according to your measurement requirement:

- **Integ BW** - Allows you to specify the integration bandwidth in which the power is measured. The range is 1.000 kHz to 10.0000 MHz with 1 or 10 Hz resolution.
- **Chan Pwr Span** - Allows you to set the frequency span for the channel power measurement. The range is 1.626 to 10 times the integration bandwidth but limited up to 10 MHz with 1 or 10 Hz resolution. This span is used for the current **Integ BW** setting. Since **Chan Pwr Span** is coupled to **Integ BW**, if you change the integration bandwidth setting, the channel power span setting changes by a proportional amount until a limit value is reached.

In addition, the following parameters for channel power measurements can be modified by pressing the **Advanced** key:

- **Sweep Time** - Allows you to manually change the sweep time and also to toggle the sweep time control between **Auto** and **Man** (manual). The range is 1.000 μ s to 50.00 ms with 1 or 10 μ s resolution. The default setting is 68.27 μ s and **Auto**.
- **Data Points** - Allows you to select the number of data points. The automatic mode chooses the optimum number of points for the fastest measurement time with acceptable repeatability. The minimum number of points that could be used is determined by the sweep time and the sampling rate. You can increase the length of the measured time record (capture more of the burst) by increasing the number of points, but the measurement will take longer.
- **Res BW** - Shows information on the resolution bandwidth derived from the sweep time.
- **Trig Source** - Allows you to choose the trigger source from **Free Run** (Immediate), **Video (IF Envl)**, **RF Burst (Wideband)**, **Ext Front** or **Ext Rear**.

Changing the Display

The **Amplitude Y Scale** key accesses the menu to set the desired vertical scale and associated settings.

- **Scale/Div** - Allows you to enter a numeric value to change the vertical display sensitivity. The range is 0.10 to 20.00 dB with 0.01 dB resolution. The default setting is 10.00 dB, however, since **Scale Coupling** is defaulted to **On**, this value is automatically determined by the measurement result.
- **Ref Value** - Allows you to enter a numeric value to change the absolute power value as the display reference. The range is 0.00 to 250.00 dBm with 0.01 dB resolution, however, since **Scale Coupling** is defaulted to **On**, this value is automatically determined by the measurement result.
- **Ref Position** - Allows you to set the display reference position to either **Top**, **Ctr** (center), or **Bot** (bottom). The default setting is **Top**.
- **Scale Coupling** - Allows you to toggle the scale coupling function between **On** and **Off**. The default setting is **On**. This function automatically determines the scale per division and reference values by the measurement results.

Troubleshooting Hints

If an external attenuator is used, be sure to include its attenuation in the measurement of the channel power. Use the **Ext Atten** key.

The channel power measurement, very often along with the adjacent channel power ratio measurement and/or spectrum measurement, can reveal degraded or defective parts in the transmitter section of the UUT. The following examples are those areas to be checked further.

- Some faults in the DC power supply control of the transmitter power amplifier, RF power controller of the pre-power amplifier stage, and/or I/Q control of the baseband stage.
- Some degradation in the gain and output power level of the amplifier due to the degraded gain control and/or increased distortion.
- Some degradation of the amplifier linearity and other performance characteristics.

Making the Adjacent Channel Power (ACP) Measurement

Purpose

Adjacent Channel Power (ACP) is the power contained in a specified frequency channel bandwidth relative to the total carrier power. It may also be expressed as a ratio of power spectral densities between the carrier and the specified offset frequency. The absolute power at the specified offset is also provided in dBm, or dBm/Hz.

As a composite measurement of out-of-channel emissions, ACP combines both in-band and out-of-band specifications to provide useful figures-of-merit for spectral regrowth and emissions produced by components and circuit blocks without the rigor of performing a full spectrum emissions mask measurement.

To maintain a quality call by avoiding channel interference, it is important to measure and reduce any adjacent channel leakage power transmitted from a mobile phone. The characteristics of adjacent channel leakage power are mainly determined by the transmitter design, particularly the low-pass filter.

Measurement Method

This measurement analyzes the total power levels within the defined carrier bandwidth and at given frequency offsets on both sides of the carrier frequency.

It uses an integration bandwidth (IBW) method that performs a time domain data acquisition and applies FFT to get a frequency domain trace. In this process, the channel integration bandwidth is analyzed using the automatically defined resolution bandwidth (RBW), which is much narrower than the channel bandwidth. The measurement computes an average power of the channel over a specified number of data acquisitions, automatically compensating for resolution bandwidth and noise bandwidth.

This measurement requires the user to specify measurement bandwidths of the carrier channel and each of the offset frequency pairs up to 5. Each pair may be defined with unique measurement bandwidths. If **Total Pwr Ref** is selected as the measurement type, the results are displayed as relative power in dBc and as absolute power in dBm. If **PSD** (Power Spectral Density reference) is selected, the results are displayed as relative power in dB, and as absolute power in dBm/Hz.

Making the Measurement

NOTE The factory default settings provide a good starting point. For special requirements, you may want to change some of the settings. Press **Meas Setup**, **More**, **Restore Meas Defaults** at any time to return all parameters for the current measurement to their default settings.

Select the desired center frequency.

Press **Measure**, **ACP** to immediately make **Adjacent Channel Power (ACP)** the active measurement.

To change any of the measurement parameters from the factory default values, refer to the “Changing the Measurement Setup” section below.

Results

The following figure shows an example result of ACP (Total Pwr Ref) measurements in the bar graph window. The absolute and relative power levels on both sides of the carrier frequency are displayed in the graphic window and text window.

Figure 5 Adjacent Channel Power Measurement - Bar Graph View

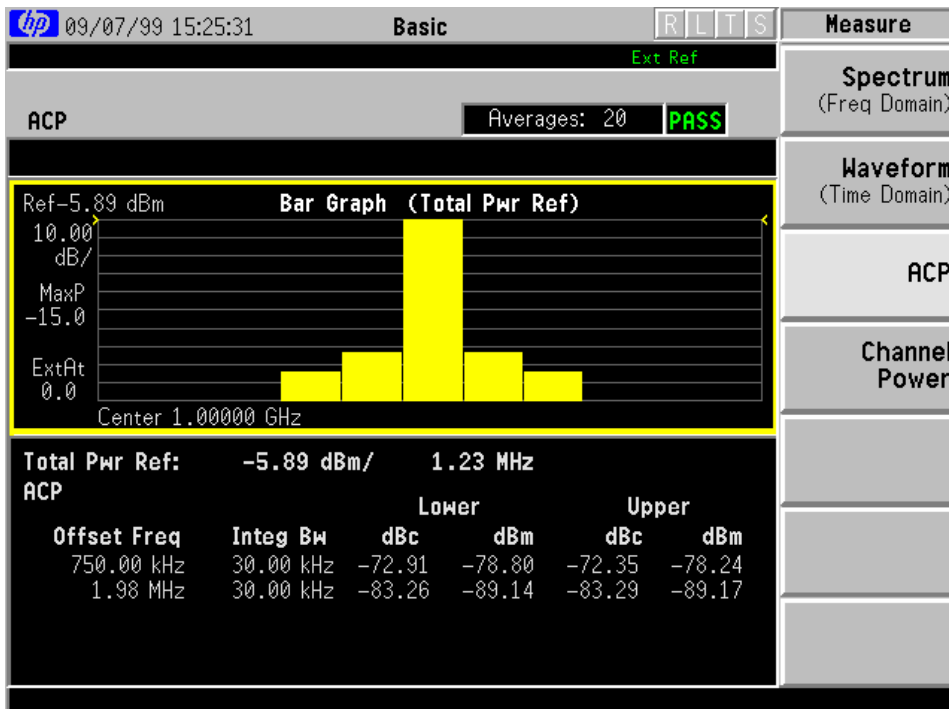
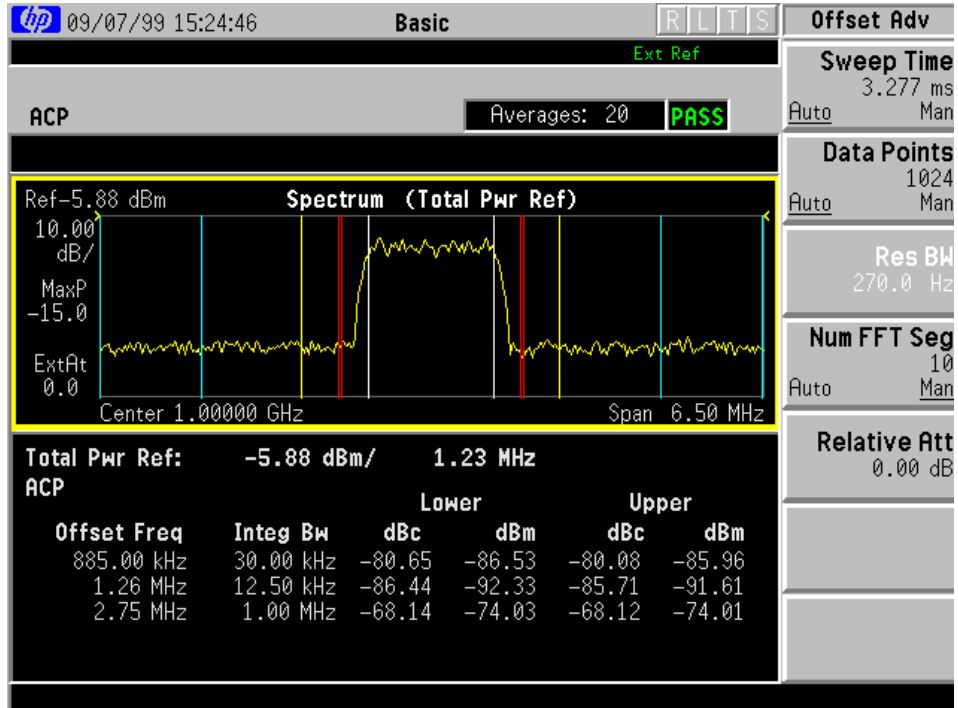

Figure 6 Adjacent Channel Power Measurement - Spectrum View



Changing the Measurement Setup

Table 4-2 Adjacent Channel Power Measurement Defaults

Measurement Parameter	Factory Default Condition
View/Trace	Bar Graph (Total Pwr Ref)
Average Number	20 On
Average Mode	Repeat
Reference Channel	
Channel Integ BW	1.23000 MHz
Avg Type	Pwr Avg (RMS)
Offset Limits	
Offset	A
Offset Freq	750.000 kHz On (offset A)
Offset Side	Both
Ref BW	30.000 kHz
Avg Type	Pwr Avg (RMS)
Limit Setup	
Abs Limit	0.00 dBm
Fail	Relative
Rel Lim (Car)	-45.00 dBc (offset A)
Rel Lim (PSD)	-28.87 dB (offset A)
Measurement Type	Total Pwr Ref
Trigger Source	Free Run (Immediate)
Limit Test	On
Advanced	
Ref Chan Adv	
Sweep Time	546.1 μ s Auto
Data Points	2048 Auto
Num FFT Seg	1 Auto
Offset Adv	
Sweep Time	11.20 ms Auto
Data Points	1024 Auto
Num FFT Seg	1 Auto
Relative Att	0.00 dB

Make sure the **ACP** measurement is selected under the **Measure** menu. The **Meas Setup** key accesses the menu which allows you to modify the average number and average mode for this measurement. In addition, the following parameters for adjacent channel power measurements can be modified.

- **Ref Channel** - Allows you to access the following parameters for the reference channel settings:

Chan Integ BW - Allows you to specify the channel integration bandwidth in which the carrier power is measured. The range is 1.000 kHz to 20.0000 MHz with the best resolution of 1 Hz.

Avg Type - Choose the averaging type between **Pwr Avg (RMS)** and **Maximum**.

Ref Chan Adv - Allows you to access the menu to change the following advanced parameters for the reference channel:

Sweep Time

Data Points - Allows you to select the number of data points. The automatic mode chooses the optimum number of points for the fastest measurement time with acceptable repeatability. The minimum number of points that could be used is determined by the sweep time and the sampling rate. You can increase the length of the measured time record (capture more of the burst) by increasing the number of points, but the measurement will take longer.

Res BW - informational only

Num FFT Seg - Allows you to select the number of FFT segments used in making the measurement of the reference channel (carrier). In automatic mode the measurement optimizes the number of FFT segments required for the shortest measurement time. The minimum number of segments required to make a measurement is set by your desired measurement bandwidth. Selecting more than the minimum number of segments will give you more dynamic range for making the measurement, but the measurement will take longer to execute.

- **Offset/Limits** - Allows you to access the menu to change the following parameters for offset frequency settings and pass/fail tests:

Offset - Allows you to select one of five offsets (**A** through **E**). Only one selection at a time (**A**, **B**, **C**, **D**, or **E**) is shown on this key label. The remaining softkeys on the **Offset/Limits** menu then apply to the selected offset.

Offset Freq- Allows you to enter an offset frequency value and toggle the offset frequency function between **On** and **Off**. The range is 0.0 Hz to 45.000 MHz. While this key is activated, enter an offset value from the numeric keypad by terminating with one of the frequency unit keys shown. Offsets **A** and **B** are defaulted as follows, while others are defaulted to 0.0 Hz:

Offset A 750.000 kHz

Offset B 1.98000 MHz

One offset frequency value corresponding to the **Offset** key selection is shown on this key label.

Offset Side - Choose **Neg** (negative) or **Pos** (positive) to have single-sided offsets relative to the carrier, or **Both** (the default) to have offset frequency pairs.

Ref BW - Allows you to enter a reference bandwidth ranging from 300 Hz to 20.0000 MHz with the best resolution of 1 Hz. When this parameter is changed, the integration bandwidth **Integ BW** in the summary data window changes to that value.

Avg Type - Choose the type of averaging between **Pwr Avg (RMS)** or **Maximum**.

Limit Setup -

Abs Limit - Allows you to enter an absolute limit value ranging from -200.00 to +50.00 dBm with 0.01 dB resolution.

Fail - Allows you to access the following menu to select one of the logic keys for fail conditions between the measurement results and the test limits:

AND - Fail is shown if one of the relative ACP measurement results is larger than **Rel Lim (Car)** or **Rel Lim (PSD)** AND one of the absolute ACP measurement results is larger than **Abs Limit**.

OR - Fail is shown if one of the relative ACP measurement results is larger than **Rel Lim (Car)** or **Rel Lim (PSD)** OR one of the absolute ACP measurement results is larger than **Abs Limit**.

Absolute - Fail is shown if one of the absolute ACP measurement results is larger than **Abs Limit**.

Relative - Fail is shown if one of the relative ACP measurement results is larger than **Rel Lim (Car)** or **Rel (PSD)**.

Rel Lim (Car)- Allows you to enter a relative limit value of the carrier level ranging from -150.00 to $+50.00$ dBc with 0.01 dB resolution. The default is -45.00 dBc for Offset A and -60.00 dBc for offset B.

Rel Lim (PSD)- Allows you to enter a relative limit value of the power spectral density level ranging from -150.00 to $+50.00$ dB with 0.01 dB resolution. The default is -28.87 dB for Offset A and -43.87 dB for offset B.

Offset Adv - Allows you to access the menu to change the following advanced offset parameters:

Sweep Time

Data Points - Allows you to select the number of data points. The automatic mode chooses the optimum number of points for the fastest measurement time with acceptable repeatability. The minimum number of points that could be used is determined by the sweep time and the sampling rate. You can increase the length of the measured time record (capture more of the burst) by increasing the number of points, but the measurement will take longer.

Res BW - informational only

Num FFT Seg - The automatic mode selects the optimum number of FFT segments to measure the offset, while making the fastest possible measurement.

Relative Att - Allows you to set a relative amount of attenuation for the measurements made at your offsets. The amount of attenuation is always specified relative to the attenuation that is required to measure the carrier channel. Since the offset channel power is lower than the carrier channel power, less attenuation is required to measure the offset channel and you get wider dynamic range for the measurement.

- **Meas Type** - Allows you to access the menu to select one of the measurement reference types.

Total Pwr Ref - Sets the reference to the total carrier power.

PSD Ref - Sets the reference to the mean power spectral density of the carrier.

- **Spectrum Trace**

Turns off the spectrum trace data calculations. This is only applicable when using the Spectrum View. It speeds up the display of the other measured data values by not calculating the spectrum trace.

Changing the View

The **View/Trace** key accesses the menu to select the desired view of the measurement.

- **Bar Graph** - In the factory default condition, 5 of the total integration power levels, centered at the carrier frequency and ± 750.0 kHz and ± 1.98 MHz offset frequencies, for example, are shown in the graph window. The corresponding measured data is shown in the text window. Depending on the **Meas Type** setting, one of the two following displays is obtained:

Bar Graph (Total Pwr Ref) - A histogram of powers referenced to the total power

Bar Graph (PSD Ref) - A histogram of powers referenced to the mean power spectral density of the carrier in dBm/Hz

- **Spectrum** - In the factory default condition, the frequency spectrum with the FFT sweep type is displayed with the bandwidth marker lines in the graph window. The corresponding measured data in the text window is the total integration power levels, in dBc and dBm, within the defined bandwidth as shown in the figure below. Depending on the **Meas Type** setting, one of the two following displays is obtained:

Spectrum (Total Pwr Ref) - A spectrum display referenced to the total power

Spectrum (PSD Ref) - A spectrum display referenced to the mean power spectral density of the carrier in dBm/Hz

You can improve the update speed of the displayed data values by turning off the spectrum trace in **Meas Setup**.

Troubleshooting Hints

This adjacent channel power ratio measurement can reveal degraded or defective parts in the transmitter section of the UUT. The following examples are those areas to be checked further.

- Some faults in the DC power supply control of the transmitter power amplifier, RF power controller of the pre-power amplifier stage, or I/Q control of the baseband stage
- Some degradation in the gain and output power level of the amplifier due to the degraded gain control and/or increased distortion
- Some degradation of the amplifier linearity and other performance characteristics

Power amplifiers are one of the final stage elements of a base or mobile transmitter and are a critical part of meeting the important power and spectral efficiency specifications. Since ACP measures the spectral response of the amplifier to a complex wideband signal, it is a key measurement linking amplifier linearity and other performance characteristics to the stringent system specifications.

Service Measurements

Service measurements help you check the functionality of your instrument. They include a power vs. time measurement, which is intended strictly for diagnostic uses.

The spectrum and waveform measurements that can be accessed through the service menu are explained in the section on basic measurements. The spectrum measurement is explained on [page 91](#), and the waveform measurement is explained on [page 99](#).

To access the Service mode press the **Mode** key and select the **Service** softkey. The following service measurements are available:

Pwr vs Time on [page 121](#)

Timebase Frequency on [page 125](#)

50 MHz Amptd on [page 127](#)

Sensors on [page 129](#)

Spectrum on [page 91](#)

Waveform on [page 99](#)

Front Panel Test on [page 131](#)

Mfg Tests (service password required)

Making the Power vs. Time Measurement

Purpose

This measurement is provided for instrument internal testing and self diagnostics.

Power vs. Time measures the mean transmit power during the “useful part” of GSM bursts and verifies that the power ramp fits the within the defined mask. Power vs. Time also lets you view the rise, fall, and “useful part” of the GSM burst.

Measurement Method

The instrument acquires a GSM signal in the time domain. The “T0” point and the useful part are computed. If Burst Sync is set to **Training Seq**, a GSM demodulation is performed to find “T0”. If Burst Sync is set to **RF Amptd**, an approximation of “T0” will be used without performing a demodulation. The average power in the useful part is then computed and displayed, and the GSM limit mask is applied. The measurement displays **Pass** when the burst fits within the bounds of the mask.

Making the Measurement

NOTE

The factory default settings provide a good starting point. For special requirements, you may need to change some of the settings. Press **Meas Setup, More (1 of 2), Restore Meas Defaults** at any time to return all parameters for the current measurement to their default settings.

Select the desired center frequency.

Press **Measure, Pwr vs Time** to immediately make Power vs. Time the active measurement.

To change any of the measurement parameters from the factory default values, refer to the [“Changing the Measurement Setup”](#) section for this measurement.

Results

Figure 4-2 Power vs. Time Measurement Result - Burst View

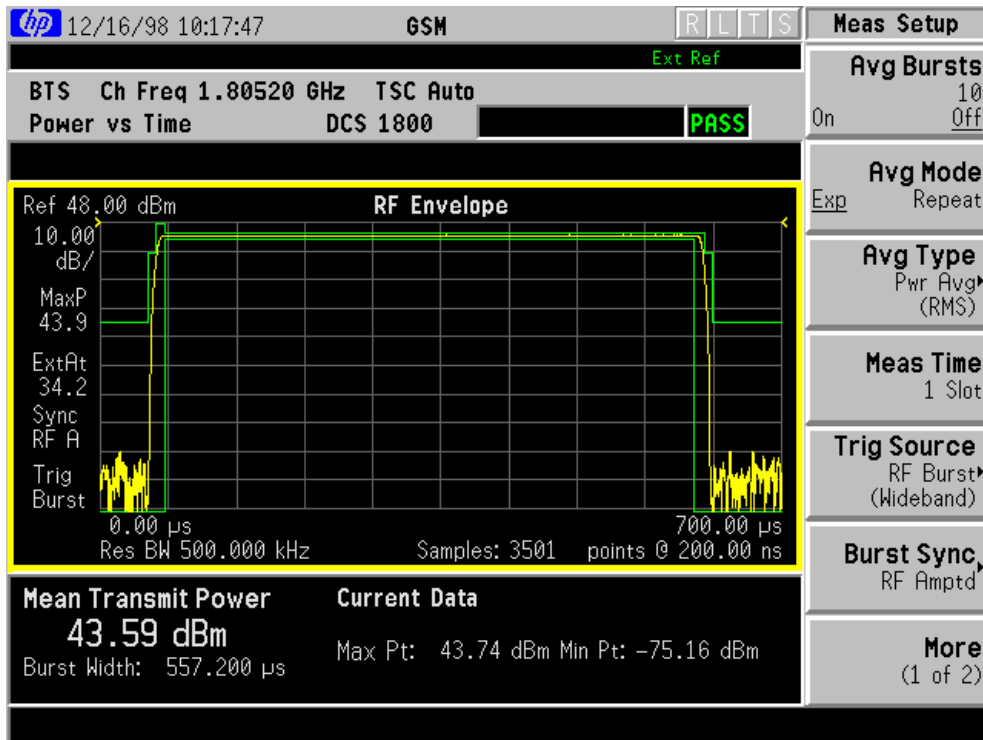
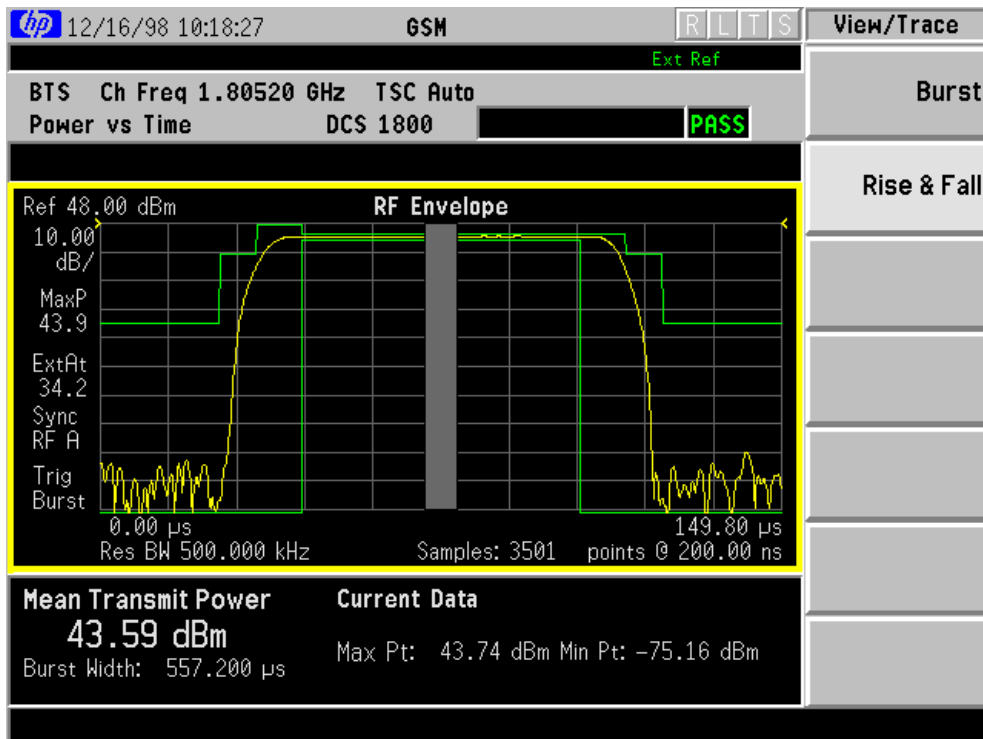

Figure 4-3 Power vs. Time Measurement Result - Rise & Fall View



Changing the Measurement Setup

Table 4-3 Power vs. Time Measurement Defaults

Measurement Parameter	Factory Default Condition
Avg Bursts	10 Off
Avg Mode	Exp
Avg Type	Pwr Avg (RMS)
Meas Time	1 Slot
Trig Source	RF Burst (Wideband)
Burst Sync	Training Seq
Advanced	
RBW Filter	Gaussian
Res BW	500.000 kHz

NOTE Parameters that are under the **Advanced** key seldom need to be changed. Any changes from the default values may result in invalid measurement data.

Make sure the Power vs. Time measurement is selected under the **Measure** menu. The **Meas Setup** key will access a menu which allows you to modify the averaging, trigger source, and burst sync for this measurement (as described in the “[Measurement Setup](#)” section at the beginning of this chapter). In addition, the following power vs. time measurement parameters can be modified:

- **Meas Time** - allows you to measure more than one timeslot. Enter a value in integer increments of “slots” with a range of 1 to 50. The actual measure time in μs is set somewhat longer than the specified number of slots in order to view the complete burst.
- **Advanced** - accesses a menu to change the following parameters:
 - **RBW Filter** - Choose the type of filter, either **Gaussian** or **Flat** (Flatop). Gaussian is the best choice when looking at the overall burst or the rising and falling edges, as it has excellent pulse response. If you want to precisely examine just the useful part of the burst, choose **Flat**.

Res BW - sets the resolution bandwidth.

Changing the View

The **View/Trace** key will access a menu which allows you to select the desired view of the measurement from the following selections:

- **Burst** - views the entire sweep as specified by the meas time.
- **Rise & Fall** - zooms in on the rising and falling portions of the burst being tested.

NOTE

The limit test will still be performed on the entire burst, (viewed using the **Burst** menu), when **Rise & Fall** is selected.

Timebase Frequency

Purpose

In the absence of a frequency counter, the measurement quickly determines the frequency difference between the instrument's 10 MHz reference oscillator signal and an accurate, external 10 MHz frequency standard.

NOTE The timebase frequency check is not as accurate as a measurement of the 10 MHz Out signal (rear panel) using a frequency counter referenced to a frequency standard.

Measurement Method

The internal 10 MHz reference signal is compared with a reliable external 10 MHz signal which the user inputs into the front panel RF connector. The transmitter tester subtracts its 10 MHz reference from the input signal and displays the frequency difference.

Test Setup

An accurate external 10 MHz frequency signal, such as a house standard, is connected to an attenuator, which attenuates the signal to 0 dB. The attenuated 10 MHz signal is connected to the RF input of the transmitter tester. Pressing **Mode**, **Service**, **Measure**, **Timebase Frequency** will result in the display of data described below.

NOTE When setting up this test ensure that the reference is set to internal. To check this press **System**, **Reference**. The **Freq Ref** softkey allows you to toggle between **Int** (internal) and **Ext** (external). Make sure **Int** is underlined.

Results

Window One (Time Record)

Shows an I/Q display of the frequency difference between the input signal and the internal 10 MHz signal.

Window Two (Magnitude)

Shows a polar representation of window one. This window shows how much the phase error changes during the sampling period.

Window Three (Freq Error)

Shows a stripchart of the timebase error in MHz vs. time. Each dot on the horizontal axis is one sampling period.

Window Four (numeric results)

Freq error: The error difference between the 10 MHz input signal and the internal 10 MHz signal.

Magnitude: The magnitude of the external 10 MHz signal. While this is an uncalibrated value, it gives the user an idea of the signal amplitude.

Adjusting: A 0 will appear if the timebase adjustment is not being performed. A 1 will appear if the adjustment is being performed.

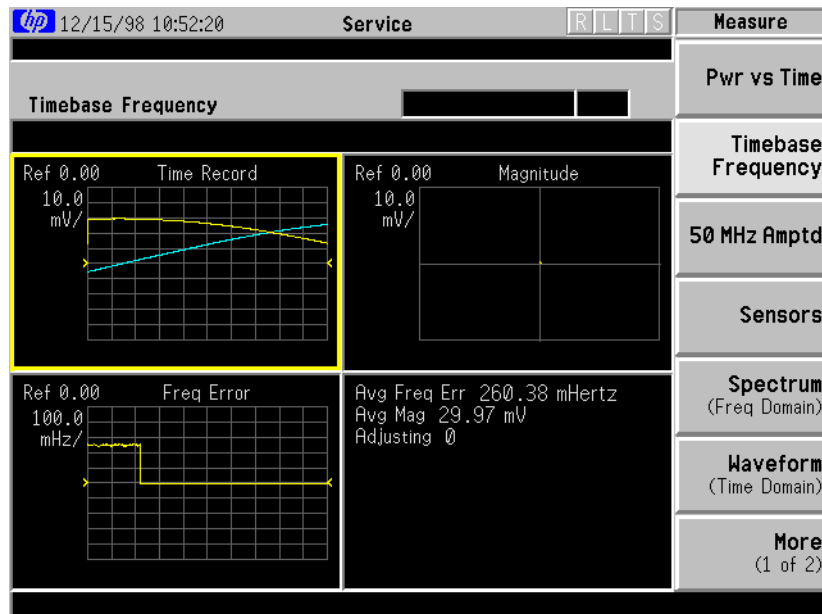

50 MHz Amplitude

Purpose

To check the amplitude of the internal 50 MHz amplitude reference signal.

Measurement Method

The amplitude of an internal 50 MHz reference signal is compared with the amplitude of a stable external 50 MHz signal which has been measured with a power meter and then connected to the front panel RF connector.

Test Setup

The 50 MHz amplitude feature enables you to measure the amplitude of the internal 50 MHz reference signal. The amplitude of an internal 50 MHz reference signal is adjusted as close as possible to -25.00 dBm, based on the relative measurement of the reliable external 50 MHz signal, which is input by the user into the front panel RF connector. Follow these steps to measure the amplitude of the 50 MHz amplitude reference signal (a power meter and a reliable external source will be needed to perform this test):

1. Set the external source to a frequency of 50 MHz at a power level of -25 dBm (± 2 dBm).
2. Connect the external source to the power meter through a cable. Adjust the power output of the source until the power meter reads -25.00 dBm, or as close to -25.00 dBm, as possible.
3. Disconnect the power sensor and connect the source to the transmitter tester.
4. Press **Mode, Service, Measure, 50 MHz Amptd** on the transmitter tester. See next page for results.

Results

Window One (RF Magnitude)

Shows the amplitude (unitless) of the external source as measured by the transmitter tester.

Window Two (Cal Magnitude)

Shows the amplitude (unitless) of the 50 MHz input calibrator.

Window Three (Error)

Shows a stripchart of the amplitude error between the 50 MHz internal calibrator and the external source amplitude.

Window Four (numeric results)

Cal Amplitude: The instrument's internal ADC level when measuring the internal 50 MHz calibrator amplitude.

RF Amplitude: The instrument's internal ADC level when measuring the external source amplitude

Error: The difference in ADC level between the 50 MHz internal calibrator amplitude and the source amplitude.

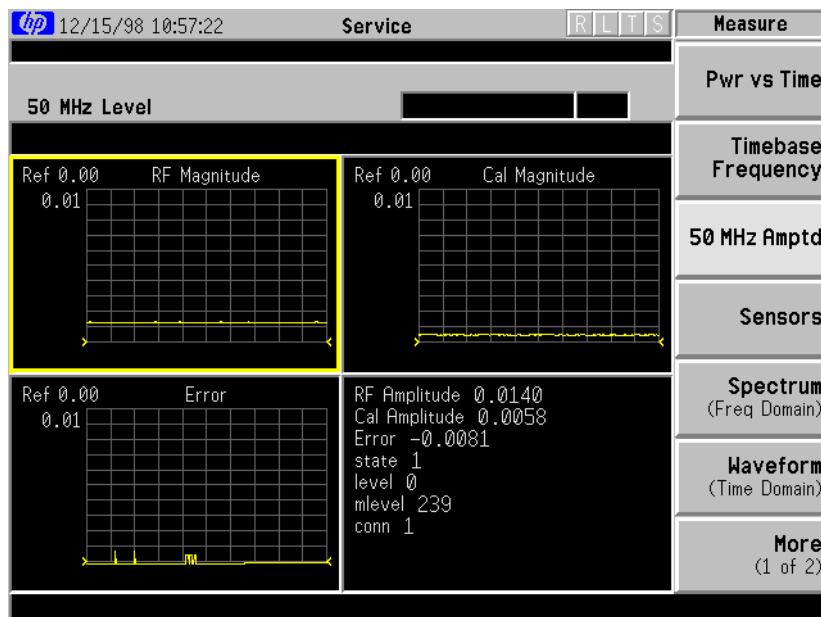

Sensors

Purpose

The temperature of the RF board will vary over time and can adversely affect the IF signal amplitude. Sensors on the RF board monitor changes in temperature.

Measurement Method

The sensor measurements are generated internally and do not require any user interaction.

Test Setup

Press **Mode**, **Service**, **Measure**, **Sensors**.

Results

Window One (IF Signal Level)

Shows a stripchart of the IF signal amplitude in dBm.

Window Two (Cal Osc Level)

The Cal Oscillator window is not implemented.

Window Three (RF Temperature)

Shows a stripchart of the RF assembly temperature in Celsius.

Window Four (numeric results)

IF Signal Level: The ADC number for the detected 21.4 MHz IF signal at the input to the AIF. Typical values with the input attenuator set to 0 dB: 20 (no signal applied); 23(- 10 dBm); 27(- 5 dBm), and 38(0 dBm).

Cal Osc Level: Not implemented.

RF Temp: Shows current temperature in Celsius.

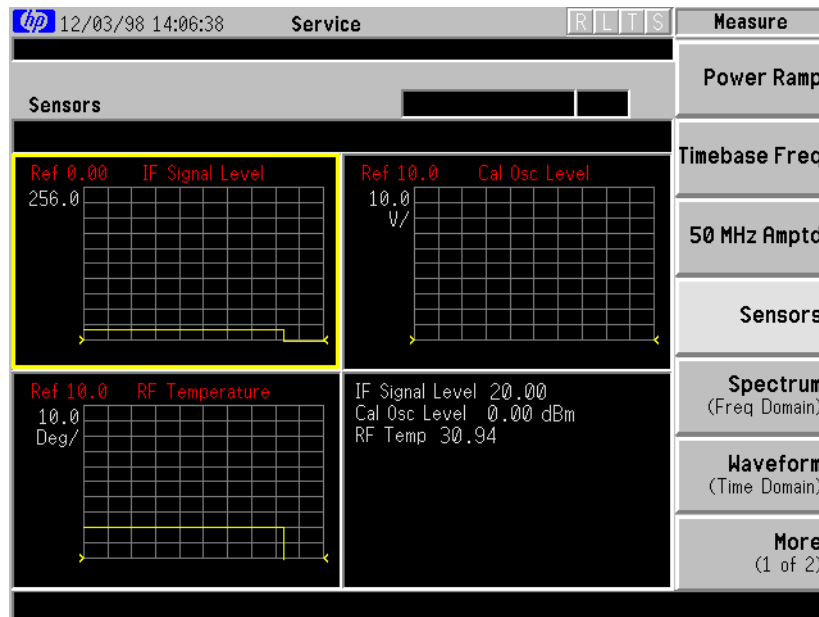

Front Panel Test

Purpose

The front panel test checks the functionality of the instrument front panel keys and the RPG knob.

Test Setup

Press **Measure, More (1 of 2), Front Panel Test**. Once the **Front Panel Test** key is pressed you will see a display with three columns appear on the screen. The entries on the left side of each column describe a key. On the right side of each entry you will see a 0.

The front panel test requires you to press each of the front panel keys (in any order, with the exception of the **ESC** key, which *must* be pressed last), and to turn the RPG knob. The first time you press a key a 1 will replace the 0 that originally appeared to the right of the key column. Each additional instance of pressing a given key will result in an increment to the number listed in the column to the right of the key description. For example if you press the **Zoom** key four times, you will see a 4 to the right of the `Zoom` entry.

Rotating the RPG knob will result in a rapidly incrementing, or decrementing value appearing in the column to the right of the `RPG Knob` entry. Rotate the RPG knob clockwise and counter-clockwise. You will see negative or positive values appear, in ascending or descending order, depending on the direction you have turned the RPG knob.

Note that the two step keys (the up and down arrow keys) are described as the `Rpg Dn` and `Rpg Up` keys.

The **ESC** key must be pressed only after all other keys have been pressed and the RPG knob has been rotated; pressing the **ESC** key will cause the front panel test to be cancelled.

Results

The display will show a list of all front panel keys and the RPG knob, followed by a “times-pressed” indicator. You will see a count of the number of times you have pressed a key next to that key on the display, except for the knob, next to which you will see positive or negative numbers in increments of 1.

```
hp 12/04/98 09:03:28 Service R L T S
Front Panel Test PASS
Press ESC When Done
0= 512: 1 1= 513: 1 2= 514: 1
3= 515: 1 4= 516: 1 5= 517: 1
6= 518: 1 7= 519: 1 8= 520: 1
9= 521: 1 .= 523: 1 Help=2560: 1
Zoom=2562: 1 Next=2561: 1 Home=2563: 1
Left=2564: 1 Right=2565: 1 Soft 1=2304: 1
Soft 2=2305: 1 Soft 3=2306: 1 Soft 4=2307: 1
Soft 5=2308: 1 Soft 6=2309: 1 Soft 7=2310: 1
Return=2311: 1 Freq=1024: 1 Input=1025: 1
Mode=1026: 1 Mod Set=1027: 1 Disp=1283: 1
Preset=1793: 1 X Scale=1280: 1 View=1281: 1
File=1794: 1 Save=1798: 1 System=1795: 1
Y Scale=1282: 2 P Setup=1796: 1 Print=1797: 5
Meas=1536: 2 Mea Set=1537: 1 Marker=2048: 1
Mkr Src=2049: 1 M Res=1538: 1 M Cntl=1539: 2
Rpg Dn= 770: 1 Rpg Up= 769: 1 +/- = 522: 1
<-= 524: 1 Enter= 525: 1 RPG= 768: 2
```

Troubleshooting Hints

If the front panel check fails contact the Agilent Technologies instrument support center. See [page 201](#).

5 **Functional Testing**

What You'll Find in This Chapter

This chapter is divided into two sections. The first, “[Getting Started](#),” is a brief description of what functional tests are and what you will need to perform them. The second, “[Test Descriptions](#),” is the test section that describes the various tests and their implementation.

What Are the Functional Tests?

Functional tests are tests of various instrument parameters that give a high degree of confidence that the instrument is operating correctly. The test will take approximately one (1) hour to complete. They are recommended as a check of instrument operation for incoming inspection or after a repair. Measurement uncertainty analysis is not available for functional tests, and the instrument is checked against specifications that are wider than the published specifications. The functional tests are designed to test an instrument operating within the operational temperature range defined by the instrument specifications using a minimum set of test equipment. If a test does not pass, the more thorough Performance Tests must be run to confirm a problem exists. The functional tests included in this chapter are found in the section titled “[Test Descriptions](#)” on page 137.

Functional Test Versus Performance Verification

Performance verification tests check a wide range of instrument parameters and provide the highest level of confidence that the instrument is operating satisfactorily and are used to verify it conforms to published specifications. They are time consuming and require extensive test equipment. The functional tests check a much smaller range of parameters and a limited number of data points for each parameter. They require only limited test equipment and check that the transmitter tester is functioning correctly, but in no way verify conformance to published specifications.

Getting Started

Before You Start

You must do the following *before* starting functional tests:

1. Ensure you have the proper test equipment, refer to [Table 5-1 on page 136](#).
2. Switch on the unit under test (UUT) and let it warm up in accordance with warm-up requirements in the instrument specifications.
3. Ensure that the frequency reference is set to internal. To check this, press **System** and **Reference**. The **Ref Oscillator** softkey should have **Int** underlined. If not, press **Ref Oscillator** until **Int** is underlined.

Test Equipment

[Table 5-1 on page 136](#) summarizes the equipment required to run the Functional tests. Some tests, like Flatness, can use various model numbers of a particular equipment type. The “Recommended Agilent Model” will provide the best results. However, the “Alternative Agilent Model” is an acceptable substitute. If neither the recommended nor the alternative test equipment are available, you may use substitute equipment that meets or exceeds the critical specifications listed in the table.

NOTE

The validity of functional test measurements depends, in part, on the measurement accuracy of the required test equipment used. Verify the proper calibration of all test equipment before running these tests.

Test Equipment Warmup

Allow sufficient warm-up time for test equipment. Refer to their individual operating or service manuals for warm-up specifications.

Equipment Connections

Test setups for each test are included with the test. These are in the section titled “[Test Descriptions](#)” on [page 137](#).

Table 5-1 Required Test Equipment Summary

Instrument	Critical Specifications	Recommended Agilent Model Number	Alternative Agilent Model Number
Signal Source			
Synthesized Signal Generator	Frequency: 7 MHz to 2.5 GHz Spectral purity: 5 to 1321 MHz SSB Phase Noise: ≤-110 dBc/Hz at 10 kHz offset and ≤-120 dBc/Hz at 30 kHz offset.	8663A	8662A 8664A 8665A 8643A 8644A w/ Option 002
Synthesized Swept Signal Generator	Frequency: 10 MHz to 4.0 GHz Harmonic level: <-40 dBc Amplitude range: +15 to -20 dBm	83620B	8360 series
Meters			
Power Meter	Must be compatible with the power sensor.	EPM- 441A (E4418A)	EMP-442A (E4419A) 437A 438A
Power Sensor	Frequency Range: 7 MHz to 4 GHz. Power Range: -25 dBm to 10 dBm SWR: ≤1.3 Type N (m)	8482A	8481A E4412A 8482A w/Option H84
Terminations			
Termination 50 Ω	Type N (m) Connector Frequency: 7 MHz to 4 GHz	909A option 012	
Miscellaneous Devices			
Power Splitter	Frequency: 1 MHz to 4.3 GHz	11667A	11667B
Cables			
Type N 2 required	Precision Type N 62 cm (24in) (m)	11500C	8120-4781
Adapters			
Type N (f) to N (f)	50 Ω	1250-1472	1250-0777
3.5 mm (f) to N (f)	50 Ω	1250-1745	

Test Descriptions

Each of the following test descriptions include the test limits (pass/fail criteria), a description of what the test does or what it measures, a list of equipment required for the performance of the test, an illustration of the test setup used, and a step by step test procedure. The tests are designed to be run on an instrument operating within the operational temperature range defined by the instrument specifications and warmed for the specified warm-up time.

The following is a list of the tests included in this section and the page number where test information can be found:

- “Frequency Response (Flatness)” on page 138
- “Amplitude Accuracy at 50 MHz” on page 143
- “Input Attenuator Accuracy at 50 MHz” on page 148
- “Displayed Average Noise Level (DANL)” on page 151
- “Phase Noise” on page 154
- “Residual Responses” on page 160

Frequency Response (Flatness)

Test Limits

Signal amplitude should remain within ± 2 dB (4 dB peak-to-peak) from 10 MHz to 4 GHz.

Test Description

The frequency response test measures amplitude error as a function of the tuned center frequency. Measurements are made at various points from 10 MHz to 4 GHz. The signal source amplitude is measured with a power meter to eliminate errors due to source flatness. The power meter is zeroed and calibrated before starting the measurement.

Required Equipment

(include cables and connectors)

Instrument	Recommended Agilent Model Number	Alternative Agilent Model Number
Synthesized Swept Signal Generator	83620B	8360 series
Power Meter	EPM- 441A (E4418A)	EMP-442A (E4419A), 437A, or 438A
Power Sensor	8482A	8481A, E4412A, or 8482A w/Option H84
Power Splitter	11667A	11667A
Cable: Type N, (2 required)	11500C	
Adapter: 3.5 mm (f) to N (f)	1250-1745	

Figure 5-1 Power Meter Zero and Calibration Setup

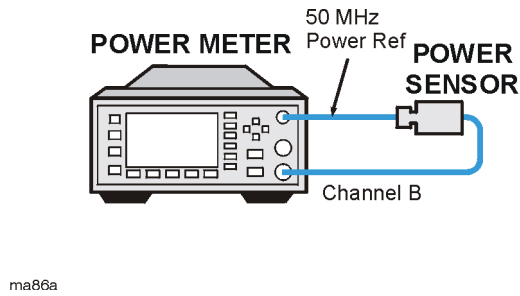
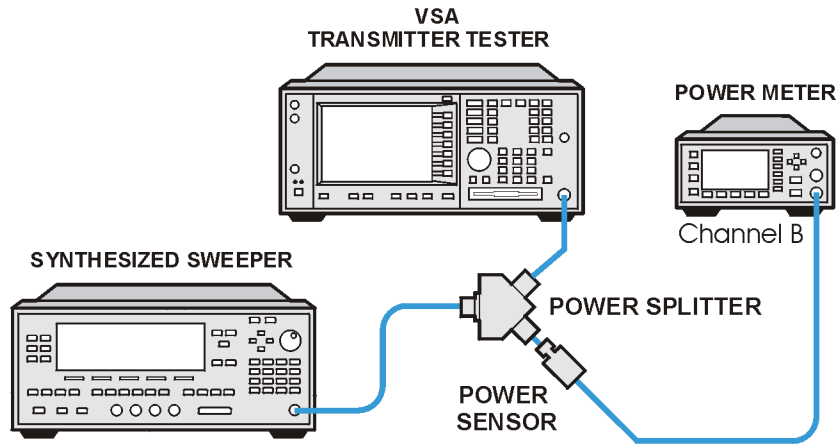

Figure 5-2 Frequency Response Test Setup



Procedure

1. Configure the power meter and power sensor as shown in [Figure 5-1](#).
2. Zero and calibrate the power meter.
3. Preset the UUT by pressing **Preset**.
4. If the auto alignment for the UUT has not been run within the last hour, run it by pressing **System, Alignment, and Align All Now**

5. Initialize the parameters for the instrument, as listed in Table 5-2, “UUT Initialization,” by performing the following steps:
 - a. Press **MODE, Basic**.
 - b. To expand the Spectrum window to full screen, ensure that the Spectrum window is highlighted and press **Zoom**.
 If the Spectrum window is not highlighted, press **Next Window** until the Spectrum window is highlighted and then press **Zoom**.
 - c. Press **FREQUENCY, Center Freq, 10, and MHz**.
 - d. Press **Input, Input Atten, 10, and dB**.
 - e. Press **Meas Setup, Average, Avg Number, 10, and Enter**.
 - f. Press **View/Trace, Trace Display, and Average**.
 - g. Press **Marker, Trace, and Spectrum Avg**.

Table 5-2 UUT Initialization

Parameter		Setting
Mode		Basic
Measure		Spectrum
Frequency	Center	10 MHz
Input Attenuation		10 dB
Average	On/Off	On
	Mode	Exp
	Type	Log-Pwr Avg
	Number	10
Trace Display		Average
Marker		Spectrum Avg

6. Preset the signal source and initialize the test equipment parameters as listed in Table 5-3, “Signal Source Initialization.”

Table 5-3 Signal Source Initialization

Parameter	Setting
Frequency	10 MHz
Amplitude	-4 dBm
RF output	On

7. Configure equipment as shown in Figure 5-2, “Frequency Response Test Setup”.
8. Adjust the synthesized sweeper amplitude for a power meter display of -10.00 dBm, ± 0.1 dB.

NOTE The power level remains unchanged for the duration of the test.

9. Press **Search** to position the marker on the peak of the signal.
10. Refer to Table 5-4, “Frequency Responses Report”. Enter the amplitude of the signal as displayed on the instrument under the UUT Amplitude Meas_{Amp} column of Table 5-4.
11. Enter the power meter reading under the Power Meter Amplitude Power_{meter} column of Table 5-4.
12. Compute the flatness error using the following equation and record the results under the Flatness Error Flat_{error} column:

$$\text{Flat}_{\text{error}} = \text{Meas}_{\text{amp}} - \text{Power}_{\text{meter}}$$

13. Perform the following steps for each frequency setting listed in Table 5-4:
 - a. Tune the source to the next frequency listed in the Center Frequency column.
 - b. Set the UUT center frequency by pressing **Frequency**, **Center**, “n”, and **MHz**. Where “n” is the next frequency value in the Center Frequency column.
 - c. Press **Search**.
 - d. Enter the power meter reading under the Power Meter Amplitude Power_{meter} column.
 - e. Enter the instrument reading under the UUT Amplitude Meas_{amp} column.
 - f. Compute the flatness error using the following equation and record the results under the Flatness Error Flat_{error} column:

$$\text{Flat}_{\text{error}} = \text{Meas}_{\text{amp}} - \text{Power}_{\text{meter}}$$

The flatness error should be less than ± 2 dB (4 dB peak-to-peak) from 10 MHz to 4 GHz.

Table 5-4 **Frequency Responses Report**

Center Frequency (MHz)	UUT Amplitude Meas_{amp} (dBm)	Power Meter Amplitude Power_{meter} (dBm)	Flatness Error Flat_{error} (dB)	Test Limits (dBm) (dB)
10				±2
400				±2
800				±2
1200				±2
1600				±2
2000				±2
2400				±2
2800				±2
3200				±2
3600				±2
4000				±2

Amplitude Accuracy at 50 MHz

Test Limits

Amplitude Accuracy should remain within ± 1 dB of the measured source value across the range of source levels and input attenuator settings.

Test Description

The amplitude accuracy test measures the absolute amplitude of the instrument at 50 MHz. A synthesized signal generator is used as the signal source for the test. A power meter is used to measure the signal source output-signal amplitude throughout the test. The value measured by the power meter is recorded as Input_i. The input attenuator of the UUT is set to various values and the source amplitude is varied using the signal generator amplitude control. The signal amplitude is measured by the power meter and the UUT at each setting and the values compared. The difference between each pair of measurements indicates the amplitude accuracy.

Required Equipment

(include cables and connectors)

Instrument	Recommended Agilent Model Number	Alternative Agilent Model Number
Synthesized Signal Generator	8663A	8662A
Power Meter	EPM- 441A (E4418A)	EMP-442A (E4419A), 437A, or 438A
Power Sensor	8482A	8481A, E4412A, or 8482A w/Option H84
Power Splitter	11667A	11667A
Cable: Type N, (2 required)	11500C	

Figure 5-3 **Amplitude Accuracy Test Setup**

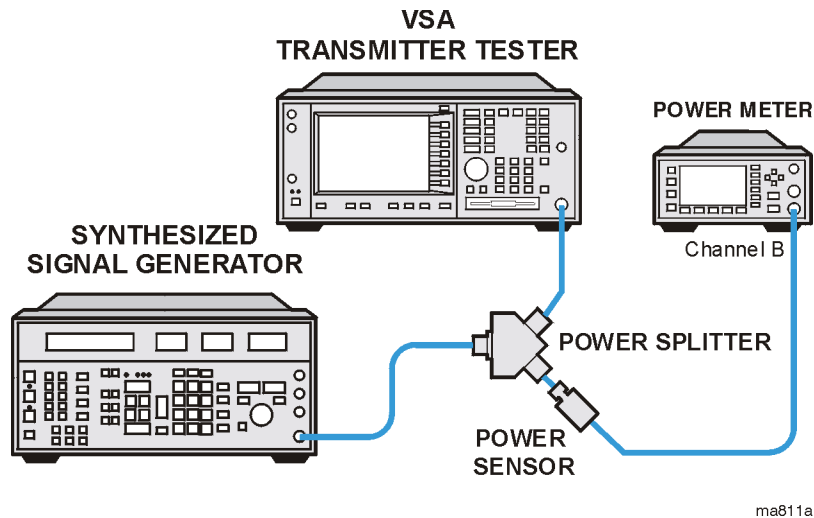

Procedure

1. Preset the UUT by pressing **Preset**.
2. If the auto alignment for the UUT has not been run within the last hour, run it by pressing **System, Alignment, and Align All Now**.
3. Initialize the parameters for the instrument, as listed in Table 5-5, "UUT Initialization," by performing the following steps:
 - a. Press **MODE, Basic**.
 - b. To expand the Spectrum window to full screen, ensure that the Spectrum window is highlighted and press **Zoom**.
If the Spectrum window is not highlighted, press **Next Window** until the Spectrum window is highlighted and then press **Zoom**.
 - c. Press **FREQUENCY, Center Freq, 50, and MHz**.
 - d. Press **Meas Setup, Average, Avg Number, 10, and Enter**.
 - e. Press **View/Trace, Trace Display, and Average**.
 - f. Press **Marker, Trace, and Spectrum Avg**.

Table 5-5 UUT Initialization

Parameter		Setting
Mode		Basic
Measure		Spectrum
Frequency	Center	50 MHz
	Span	1 MHz
Resolution Bandwidth		20 kHz
Input Attenuation		0 dB
Average	On/Off	On
	Mode	Exp
	Type	Log-Pwr Avg
	Number	10
Trace Display		Average
Marker		Spectrum Avg

4. Preset the signal source and initialize the test equipment parameters as listed in Table 5-6, “Signal Source Initialization.”

Table 5-6 Signal Source Initialization

Parameter	Setting
Frequency	50 MHz
Level	5 dBm

5. Configure the equipment as shown in Figure 5-3, “Amplitude Accuracy Test Setup.”
6. Perform the following steps for each of the nominal measured values listed in Table 5-7, “Measurement Settings”:
 - a. Set the signal source amplitude to the value listed in the Nominal Source Amplitude column in [Table 5-7](#).
 - b. On the UUT, press **Restart** and **Search**.
 - c. Wait for the transmitter tester to finish averaging.
 - d. Adjust the source amplitude, as measured on the UUT, to ± 0.5 dBm of the value listed in the Nominal Measured Value column in [Table 5-7](#).

- e. Record the signal amplitude, as measured by the power meter, in the Amplitude Input_i column of Table 5-8, “Amplitude Accuracy at 50 MHz Report.”
- f. Press **Restart**.
- g. Wait for the transmitter tester to finish averaging, and read the marker value.
- h. Record the signal amplitude, as measured by the UUT, in the Measured Amplitude X_i column of Table 5-8.

Table 5-7 Measurement Settings

UUT Nominal Measured Values (dBm)	Nominal Source Amplitude (dBm)	UUT Input Attenuator (dB)
-2	5	0
-12	-5	0
-22	-15	0
2	9	4
-12	-5	4
-22	-15	4
3	10	5
-7	0	5
-17	-10	5
8	15	10
-12	-5	10
-2	5	21

- i. Calculate the amplitude accuracy using the following equation and record in the Error Amp_Acc_i column of Table 5-8:

$$\text{Error Amp_Acc}_i = \text{Input}_i - X_i$$

Table 5-8 Amplitude Accuracy at 50 MHz Report

UUT Nominal Measured Values (dBm)	Input Atten (dB)	Power Meter Amplitude Input_i (dBm)	UUT Measured Amplitude X_i (dBm)	Error Amp_Acc_i (dB)	Test Limits (dB)
-2	0				±1.0
-12	0				±1.0
-22	0				±1.0
2	4				±1.0
-12	4				±1.0
-22	4				±1.0
3	5				±1.0
-7	5				±1.0
-17	5				±1.0
8	10				±1.0
-12	10				±1.0
-2	21				±1.0

Input Attenuator Accuracy at 50 MHz

Test Limits

The internal input attenuator should reduce the input signal to a value within ± 1.0 dB of the nominal value at 50 MHz.

Test Description

The input attenuator accuracy test checks the proper function of the internal attenuator. The attenuation is checked by using the internal 50 MHz calibration signal as a source. The input attenuator of the instrument is set to various values. The internal 50 MHz calibration signal source amplitude is constant. The signal amplitude is measured by the UUT at the 10 dB attenuator setting and recorded as the reference level. Then the signal amplitude is measured by the UUT at additional settings and the measured values compared to the reference level. Because the measured level of the input signal should not vary with changes in input attenuation, the difference between the reference value and the other measured values indicates the attenuator accuracy.

Required Equipment

None

Procedure

1. If the auto alignment for the UUT has not been run within the last hour, run it by pressing **System**, **Alignment**, and **Align All Now**
2. Preset the UUT by pressing **Preset**.
3. Initialize the parameters for the instrument, as listed in Table 5-9, "UUT Initialization," by performing the following steps:
 - a. Press **MODE** and **Basic**.
 - b. To expand the Spectrum window to full screen, ensure that the Spectrum window is highlighted and press **Zoom**.
If the Spectrum window is not highlighted, press **Next Window** until the Spectrum window is highlighted and then press **Zoom**.
 - c. Press **FREQUENCY**, **Center Freq**, **50**, and **MHz**.
 - d. Press **SPAN**, **Span**, **20**, and **kHz**.
 - e. Press **Input**, **Input Atten**, **10**, and **dB**.
 - f. Press **Input**, **Input Port**, and **50 MHz Ref**.

- g. Press **View/Trace**, **Trace Display**, and **Average**.
- h. Press **Amplitude**, **Ref Value**, **-23**, and **dBm**.
- i. Press **Marker**, **Trace**, and **Spectrum Avg**.

Table 5-9

UUT Initialization

Parameter		Setting
Mode		Basic
Measure		Spectrum
Reference Level		-23 dBm
Frequency	Center	50 MHz
	Span	20 kHz
Resolution Bandwidth		400 Hz
Input Port		50 MHz Ref
Input Attenuation		10 dB
Average	On/Off	On
	Mode	Exp
	Type	Log-Pwr Avg
	Number	25
Trace Display		Average
Marker		Spectrum Avg

- 4. Measure the reference value by performing the following steps:
 - a. Press **Search**.
 - b. Record the marker value as X_{ref} in the Measured Value X_i column of Table 5-10, "Measurement Settings."
- 5. Perform the following steps for each attenuator setting listed in [Table 5-10](#):
 - a. Press **Input**, **Input Atten**, "n", and **dB**. Where "n" is the attenuation value in the Input Attenuator column of [Table 5-10](#).
 - b. Press **Restart**.
 - c. Press **Search**.
 - d. Read the marker value in dBm.

- e. Record the measured value in the Measured Value X_i column of Table 5-10

Table 5-10 Measurement Settings

Input Attenuator (dB)	Measured Value X_i (dBm)
0	
1	
2	
4	
5	
10	$X_{ref} =$
20	
40	

6. Calculate attenuator accuracy for each attenuator setting using the following equation:

$$\text{Attenuator_Error}_i = X_i - X_{ref}$$

7. Record the attenuator error in the Attenuator Error column of Table 5-11, "Attenuator Check at 50 MHz."

Table 5-11 Attenuator Check at 50 MHz

Input Attenuator (dB)	Attenuator Error (dB)	Limit (dB)
0		± 1.0
1		± 1.0
2		± 1.0
5		± 1.0
10 ^a	0 ^a	± 1.0
20		± 1.0
40		± 1.0

- a. The zero dB setting is the reference level.

Displayed Average Noise Level (DANL)

Test Limits

The DANL test results should be within the following limits in the four frequency ranges tested:

Table 5-12

Frequency	Limits (dBm)
7 MHz to 20 MHz	≤ -90
20 MHz to 2 GHz	≤ -106
2 GHz to 3 GHz	≤ -103
3 GHz to 4 GHz	≤ -98

Test Description

The DANL test is a measurement of the noise generated internally by the instrument. With the RF 50 Ω input terminated in a 50 Ω load, the DANL is measured at several frequencies. A visual check is made to ensure the measurement is not done in the presence of a spurious response.

Required Equipment

Instrument	Recommended Agilent Model Number	Alternative Agilent Model Number
Termination 50 W	909A option 012	

Figure 5-4 DANL/Noise Figure Test Setup

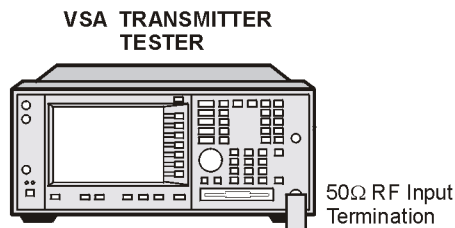

ma817a

Procedure

1. If the auto alignment for the UUT has not been run within the last hour, run it by pressing **System**, **Alignment**, and **Align All Now**.
2. Preset the UUT by pressing **Preset**.
3. Initialize the parameters for the instrument, as listed in Table 5-13, “UUT Initialization,” by performing the following steps:
 - a. Press **MODE** and **Basic**.
 - b. To expand the Spectrum window to full screen, ensure that the Spectrum window is highlighted and press **Zoom**.
 If the Spectrum window is not highlighted, press **Next Window** until the Spectrum window is highlighted and then press **Zoom**.
 - c. Press **FREQUENCY**, **Center Freq**, 19.995, and **MHz**.
 - d. Press **SPAN**, **Span**, 10, and **kHz**.
 - e. Press **Meas Setup**, **Res BW**, 1, and **kHz**.
 - f. Press **Meas Setup**, **Average**, **Avg Number**, 100, and **Enter**.
 - g. Press **View/Trace**, **Trace Display**, and **Average**.
 - h. Press **AMPLITUDE**, **Ref Scale/Div**, 5, and **dB**.
 - i. Press **AMPLITUDE**, **Ref Value**, -85, and **dBm**.

Table 5-13

UUT Initialization

Parameter		Setting
Mode		Basic
Measure		Spectrum
Frequency	Center	19.995 MHz
	Span	10 kHz
Resolution Bandwidth		1 kHz
ADC Range	Auto/On/Off	Auto
Input Attenuation		0 dB
Average	On/Off	On
	Mode	Exp
	Type	Log-Pwr Avg
	Number	100
Y Scale	Ref Value	-85 dBm
	dB/Div	5 dB

Table 5-13 UUT Initialization (Continued)

Parameter	Setting
Trace Display	Average

4. Connect 50 Ω termination to RF input of the UUT.

NOTE

Ensure that you perform the measurement on the noise floor and not on a residual response within the displayed 10 kHz span. If a residual response appears, disregard the residual response when making the measurement.

5. Measure the average amplitude of the displayed noise level by performing the following steps:

- a. Determine the average amplitude of the displayed noise floor by visual inspection.
- b. Set the marker to a point on the trace that is representative of the average value of the display noise floor by pressing **Marker**, **Trace**, and **Spectrum Avg**. Then adjust the RPG knob until the marker is set on the average value point.
- c. Read the marker value and then enter the average amplitude value into the Measured DANL column of Table 5-14, “DANL Data Sheet.”

6. Perform the following steps for each frequency setting listed in [Table 5-14](#):

- a. Press **Frequency**, **Center**, “n”, and **MHz**. Where “n” is the next frequency value in the Center Frequency column.
- b. Wait for the instrument to finish averaging.
- c. Ensure that the marker is not on a residual responses peak, read the marker value (if necessary, adjust to a point representative of the average noise value), and enter this value into [Table 5-14](#).

7. Compare the measured DANL levels against the test limits listed in [Table 5-14](#).

Table 5-14 DANL Data Sheet

Center Frequency (MHz)	Measured DANL (dBm)	Test Limits (dBm)
19.995		≤ -90
1999.995		≤ -106
2999.995		≤ -103
3999.995		≤ -98

Phase Noise

Test Limits

Center Frequency (MHz)	Frequency Offset (kHz)	Limit (dBc/Hz)
600	10	≤ -85
600	30	≤ -90
900	10	≤ -80
900	30	≤ -90
1900	10	≤ -70
1900	30	≤ -90

Test Description

The phase noise test verifies that phase noise is within acceptable limits. In this test, the source is connected to the RF Input. With the input attenuator set to 10 dB, the source output amplitude is adjusted to a 7 dBm. Input attenuation and source level remain unchanged throughout the test. The noise marker function is used to measure the phase noise at various offsets from the center frequency.

NOTE

When phase noise is measured, the phase noise of the source and the UUT are combined. Phase noise components only add, and therefore the phase noise of the source is an important consideration. The limits and measurement points for this test have been established for a source with an absolute SSB Phase Noise of ≤ 110 dBc at 10 kHz offset and ≤ 120 dBc at 30 kHz offset. If you are using a source other than those recommended in [Table 5-1 on page 136](#), ensure that it meets the critical specifications listed. However, if your source does not meet these specifications, you can complete the test by increasing the test limits. Alternatively, the spectral purity of most sources can be improved by connecting the source frequency reference to a house reference (usually 10 MHz).

Required Equipment

(include cables and connectors)

Instrument	Recommended Agilent Model Number	Alternative Agilent Model Number
Synthesized Signal Generator	8663A	8662A, 8664A, 8665A, 8643A, or 8644A w/ Option 002
Cable: Type N, (2 required)	11500C	

Figure 5-5 Phase Noise Test Setup

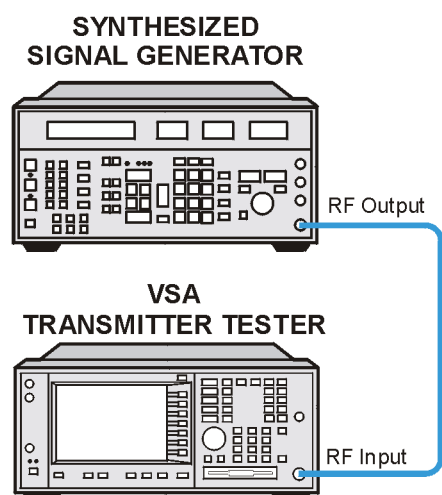

ma82a

Procedure

1. If the auto alignment for the UUT has not been run within the last hour, run it by pressing **System**, **Alignment**, and **Align All Now**.
2. Preset the UUT by pressing **Preset**.
3. Initialize the parameters for the instrument, as listed in Table 5-15, "UUT Initialization," by performing the following steps:
 - a. Press **MODE**, and **Basic**.
 - b. To expand the Spectrum window to full screen, ensure that the Spectrum window is highlighted and press **Zoom**.

If the Spectrum window is not highlighted, press **Next Window** until the Spectrum window is highlighted and then press **Zoom**.

- c. Press **Marker, Trace, Spectrum Avg.**
- d. Press **FREQUENCY, Center Freq, 600, and MHz.**
- e. Press **SPAN, Span, 800, and Hz.**
- f. Press **Input, Input Atten, 10, and dB.**
- g. Press **Meas Setup, More** until (2 of 2) is displayed, **Advanced, More** until (2 of 2) is displayed, and **ADC Dither** until On is underlined.
- h. Press **Meas Setup, More** until (2 of 2) is displayed, **Advanced, ADC Range, Manual,** and **-6 dB.**
- i. Press **Meas Setup, More** until (2 of 2) is displayed, **Advanced,** and **Pre-ADC BPF,** until Off is underlined.
- j. Press **Meas Setup, Average, Avg Number, 5, and Enter.**
- k. Press **Meas Setup, Average, Avg Type, and Pwr Avg (RMS).**
- l. Press **View/Trace, Trace Display, and Average.**

Table 5-15

UUT Initialization

Parameter		Setting
Mode		Service
Measure		Spectrum
Frequency	Center	600 MHz
	Span	800 Hz
Resolution Bandwidth		Auto
Attenuation		10 dB
Average	On/Off	On
	Mode	Exp
	Type	RMS
	Number	5
ADC Range	Manual	-6
ADC Dither	On/Off	On
Pre ADC BPF	On/Off	Off
Trace Display		Average
Marker 1		Spectrum Avg

4. Preset the signal source and initialize the parameters as shown in Table 5-16, “Synthesizer Signal Generator Initialization.”

Table 5-16 Synthesizer Signal Generator Initialization

Parameter	Setting
Frequency	600 MHz
Function	Sine Wave
Amplitude	7 dBm

5. Configure the test equipment as shown in Figure 5-5, “Phase Noise Test Setup.”
6. Perform the following steps to establish the source reference amplitude:
- Set the signal source frequency to 600 MHz.
 - If the trace is not on the display, adjust the amplitude reference value by pressing **Amplitude** and **Ref Value**. Then use the RGB knob to adjust the reference value to bring the trace onto the display.
 - Press **Search**.
 - Adjust the source amplitude until the UUT measures $7 \text{ dBm} \pm 0.5$.
 - Press **Restart**.
 - Wait for the transmitter tester to finish averaging.
 - Read the marker value in dBm.
 - Record the measured value as $Y_{i \text{ ref}}$

$$Y_{i \text{ ref}} = \text{_____ dBm}$$

7. Reset the UUT parameters to measure the phase noise by performing the following steps:
 - a. Press **Meas Setup, Res BW, 5, Hz**.
 - b. Press **Meas Setup, More** until (2 of 2) is displayed, **Advanced, ADC Range, and Auto**.
 - c. Press **Meas Setup, More** until (2 of 2) is displayed, **Advanced, and Pre-ADC BPF**, until On is underlined.
 - d. Press **Marker, Function, and Noise**.

Table 5-17

UUT Initialization

Parameter		Setting
Frequency	Center	Center Frequency
Resolution Bandwidth		5 Hz
Pre ADC BPF	On/Off	On
ADC Range	Auto/On/Off	Auto
Marker	Frequency	Noise Marker Frequency

8. If the trace is not on the display, adjust the amplitude reference value by pressing **Amplitude** and **Ref Value**. Then use the RGB knob to adjust the reference value to bring the trace onto the display.
9. Perform the following steps for each frequency setting listed in Table 5-18, "Measurement Settings":

- a. Set the signal source frequency to the value listed in the Source Frequency column of [Table 5-18](#).
- b. Set the center frequency on the UUT by pressing **FREQUENCY, Center Freq, "n", and MHz**. Where "n" is the frequency value in the Center Frequency column.

For example:

Press **FREQUENCY, Center Freq, 600.010000, and MHz**.

- c. Set the noise marker frequency by pressing **Marker, "n", and MHz**. Where "n" is the frequency value in the Noise Marker Frequency column.

For example:

Press **Marker, 600.010000, and MHz**.

Table 5-18 Measurement Settings

Source Frequency (MHz)	Center Frequency (MHz)	Noise Marker Frequency (MHz)
600	600.010000	600.010000
600	600.030000	600.030000
900	900.010000	900.010000
900	900.030000	900.030000
1900	1900.010000	1900.010000
1900	1900.030000	1900.030000

- d. Press **Restart**.
- e. Wait for the instrument to finish averaging.
- f. Read the noise marker value in dBm.
- g. Record the measured value in the Measured Y_i dBm/Hz column in Table 5-19, “Phase Noise Report.”
- h. Calculate the phase noise in dBc/HZ using the following equation and record in the Calculated Y_i dBc/Hz column of Table 5-19.

$$Y_i \text{ dBc/Hz} = Y_i \text{ dBm/Hz} - Y_{i \text{ ref}}$$

Table 5-19 Phase Noise Report

Carrier Frequency (MHz)	Frequency Offset (kHz)	Measured Y_i dBm/Hz (dBm/Hz)	Calculated Y_i dBc/Hz (dBc/Hz)	Test Limit (dBc/Hz)
600	10			≤ -85
600	30			≤ -90
900	10			≤ -80
900	30			≤ -90
1900	10			≤ -70
1900	30			≤ -90

Residual Responses

Test Limits

Frequency Range	Limit
20 MHz to 2 GHz	≤ -85
2 GHz to 4 GHz	≤ -80

Test Description

The residual response test measures the instrument residual responses. With the RF 50 Ω input terminated in a 50 Ω load, internal residual responses are measured at various frequencies between 50 MHz and 4 GHz. There are multiple residual responses across the frequency spectrum of the instrument. The residual responses are measured at only a few representative frequency points.

Required Equipment

Instrument	Recommended Agilent Model Number	Alternative Agilent Model Number
Termination 50 W	909A option 012	

Figure 5-6

Residual Responses Test Setup

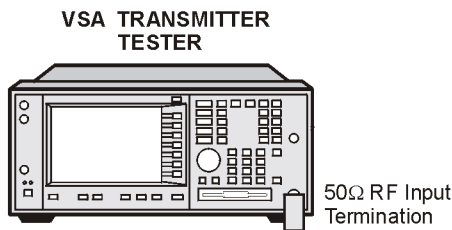

ma817a

Procedure

1. If the auto alignment for the UUT has not been run within the last hour, run it by pressing **System**, **Alignment**, and **Align All Now**
2. Preset the UUT by pressing **Preset**.
3. Initialize the parameters for the instrument, as listed in Table 5-20, “UUT Initialization,” by performing the following steps:

- a. Press **MODE** and **Basic**.
- b. To expand the Spectrum window to full screen, ensure that the Spectrum window is highlighted and press **Zoom**.
If the Spectrum window is not highlighted, press **Next Window** until the Spectrum window is highlighted and then press **Zoom**.
- c. Press **Marker**, **Trace**, and **Spectrum Avg**.
- d. Press **FREQUENCY**, **Center Freq**, **50**, and **MHz**.
- e. Press **SPAN**, **Span**, **5**, and **MHz**.
- f. Press **Meas Setup**, **More** until (2 of 2) is displayed, **Advanced**, **More** until (2 of 2) is displayed, and **ADC Dither** until Off is underlined.
- g. Press **Meas Setup**, **More** until (2 of 2) is displayed, **Advanced**, **ADC Range**, and **Auto**.
- h. Press **View/Trace**, **Trace Display**, and **Average**.
- i. Press **Amplitude**, **Ref Value**, **20**, and **dB**.

Table 5-20

UUT Initialization

Parameter		Setting
Mode		Basic
Measure		Spectrum
Frequency	Center	50 MHz
	Span	5 MHz
Resolution Bandwidth		10 kHz
Attenuation		0 dB
Average	On/Off	On
	Mode	Exp
	Type	Log-Pwr Avg
	Number	25
ADC Rang	Auto/On/Off	Auto
ADC Dither	On/Off	Off
Pre ADC BPF	On/Off	On
Trace Display		Average
Marker 1		Spectrum Avg

4. Configure the test equipment as shown in Figure 5-6, “Residual Responses Test Setup.”

5. Perform the following steps for each frequency setting listed in Table 5-21, “Measurement Settings”:

- a. Set the center frequency by pressing **FREQUENCY**, **Center Freq**, “n”, and **MHz**. Where “n” is the frequency value in the Center Frequency column.

For example:

Press **FREQUENCY**, **Center Freq**, 50, and **MHz**.

- b. Set the frequency span by pressing **SPAN**, **Span**, “n”, and **MHz**. Where “n” is the frequency value in the Span Frequency column.

For example:

Press **SPAN**, **Span**, 5, and **MHz**.

- c. Set the resolution bandwidth by pressing **Meas Setup**, **Res BW**, “n”, and **kHz**. Where “n” is the frequency value in the Res BW column.

For example:

Press **Meas Setup**, **Res BW**, 10, and **kHz**.

Table 5-21

Measurement Settings

Center Frequency (MHz)	Span Frequency (MHz)	Res BW (kHz)
50.00	5	10
740.00	2	7
1804.00	2	7
1917.90	2	7
1990.80	2	7
1992.90	2	7
3768.30	2	5
3899.50	2	5
3900.00	2	5

- d. Press **Search**.
- e. Wait for the instrument to finish averaging.
- f. Read the marker value in dBm.

- g. Record the measured value as X_i in the Measured X_i column of Table 5-22, “Residual Response Report.”

Table 5-22 **Residual Response Report**

Carrier Frequency (MHz)	Measured X_i (dBm)	Test Limit (dBm)
50.00		≤ -85
740.00		≤ -85
1804.00		≤ -85
1917.90		≤ -85
1990.80		≤ -85
1992.90		≤ -85
3768.30		≤ -80
3899.50		≤ -80
3900.00		≤ -80

6

If You Have a Problem

- helps you identify causes of problems you might experience
- explains error messages
- provides warranty information
- provides information on how to return the instrument to Agilent Technologies, if it needs service

Problem Symptoms and Solutions

The following section describes some transmitter tester problem symptoms and possible solutions to those problems. They include:

“Key or Feature Does Not Appear in Menu” on page 166

“Frequency Unlock or External Reference Missing - Error Messages” on page 167

“LAN External Loopback Test Failed - Error Message” on page 167

“Instrument Fails Alignment - Error Message” on page 167

“Measurement Keys Do Not Appear after Pressing the Mode Key” on page 168

“Instrument Power-On Problem” on page 168

“LAN Communication Problem” on page 168

Key or Feature Does Not Appear in Menu

Symptom: You are unable to locate a key for a feature you want to use in a particular measurement.

Solution 1: Many features are available only for making specific measurements, and do not apply to other measurements. Verify that the feature you are seeking is available for that particular measurement by examining the key access table on [page 53](#). Notes in the key access path column indicate whether a feature can only be used with a particular measurement. You can also review the section which documents the measurement you are using, and indicates which features apply to that measurement.

Solution 2: Some features are only available when using a specific mode. Review the section describing the mode to verify that a feature is available.

Solution 3: Some features of the transmitter tester are not yet available and will be implemented with a future firmware release. For an update on the status of firmware upgrades you can check the following URL: www.agilent.com/find/vsa/.

Frequency Unlock or External Reference Missing - Error Messages

Symptom: A frequency unlock error message, or an external reference missing error message, appears in the annunciator bar just above the data window.

Solution 1: The *red* Ext Ref message indicates that the external reference is not locked. The external reference can be any frequency between 1 and 30 MHz. If you have connected an external reference you must enter its frequency into the instrument. The value you entered must correspond to the external reference that is in use, or it will generate the error. Note that the value entered for the external reference frequency will persist, even after the instrument has been powered off and then on.

A *green* Ext Ref message indicates that the instrument is using an external reference and it is properly locked.

Solution 2: If you want to use the internal reference signal, toggle the Freq Ref key to the Int (internal) setting.

LAN External Loopback Test Failed - Error Message

Symptom: During booting the instrument you see a message which reads LAN external loopback test failed.

Solution: This message indicates that no LAN cable is connected to the instrument. You can ignore this message if you don't want to use the LAN.

Instrument Fails Alignment - Error Message

Symptom: An error message indicates that the instrument has failed alignment. This message appears either at power on during the self-alignment, or when the **Align All Now** key is pressed.

Solution: These alignments will fail if an external 50 MHz signal, at a power level greater than 0 dB, is connected to the RF input of the transmitter tester. Remove the 50 MHz signal to fix this problem.

Measurement Keys Do Not Appear after Pressing the Mode Key

Symptom: After pressing the **MODE** key, you have selected a particular mode (like **Basic**, **Service**, or one of the measurement personalities), but the menu for the mode you have selected does not appear on the softkeys.

Solution: If you were already in the mode that you selected, you must press the **MEASURE** key to display the available measurements.

Instrument Power-On Problem

Symptom: The instrument will not power-on. The instrument is plugged in, but the green LED above the front panel power switch is not on. The yellow standby LED may be flashing or may be extinguished. Something appears to be causing the instrument power supply to shut down.

Solution: An external device or internal assembly is causing the instrument to shut down, or the power supply may be in thermal shutdown. Inspect the instrument to ensure that it is receiving adequate air flow. Disconnect all devices from the rear panel and remove anything connected to the front panel probe power jack. If after powering the instrument off, the instrument powers on, determine which device caused the problem.

LAN Communication Problem

Symptom: You cannot communicate with the instrument over the LAN.

Solution: Make sure that the correct IP address has been stored in the instrument by pressing **System, Config I/O**, and then reading the IP address and Host name. If the **Restore Sys Defaults** key has been used recently both the IP address and the Host name will have been reset to factory defaults. (The IP address is deleted and the Host name is set to VSA.)

Error Queues

If an error condition occurs in the instrument, it may be reported to both the history error queue (front panel display) and the SCPI error queue (remote interface). These two queues are viewed and managed separately. Some programming errors are not applicable to front panel operation, so they are only reported through the SCPI remote interface error queue.

Error messages will appear as they occur in the Status/Info bar that appears at the bottom of the display. To view error messages fully you will use keys in the **System, Show Errors** menu.

NOTE

If there are any messages in the history error queue, the `Err` annunciator will be activated on the instrument display.

Front Panel Error Messages

Annunciators

The display annunciators show the status of some of the transmitter tester functions and indicate error conditions of the instrument. Error annunciators are shown in red text on the instrument display. Where applicable, some states will appear in green, indicating that the feature is active and performing correctly. The state will change to red if the feature fails. The following annunciators are available:

`Unlock` - This annunciator indicates that one or more of the internal phase-locked loops are unable to maintain a phase-locked state.

`Corr Off` (corrections off) - This annunciator appears when the **Corrections** softkey is set to off.

`Err` (error) - This annunciator appears when an error message is placed in the history error queue. It will persist until you use the **Clear Error Queue(s)** key to clear the history error queue.

`Ext Ref` (external reference) - The green `Ext Ref` annunciator indicates that the external reference has been selected and the instrument is locked to it. The red `Ext Ref` annunciator indicates that the external reference has been selected, but the instrument is not locked to that reference. Note that the external reference on this instrument can be set at any frequency between 1 and 30 MHz; if the entered value does not correspond to the external reference that is in use, a red `Ext Ref` annunciator will appear. Also, be aware that the value entered for the external reference frequency will persist, even after the instrument has been powered off. The user must manually enter a new value for the external reference if a different value is required, even if it corresponds with the default value. An `Ext Ref`

annunciator will appear only if the external reference has been activated by the user.

E_{Sec} (even second clock) - The green **E_{Sec}** annunciator indicates that the external even second clock has been selected as the sync type and a sync signal is present at the even second input (rear panel Trigger In), and the measurement is using it as the demodulation sync type. The red **E_{Sec}** annunciator indicates that an external even second clock has been selected as the sync type but a sync signal is not present at the even second input (rear panel Trigger In). In this case, the error message **Even Second Clock Missing** will appear in the Status/Info bar at the bottom of the display. The even second clock detection is updated every 2 seconds.

The History Error Queue

This queue is designed in a circular (rotating) fashion. It can hold up to 250 error messages. If the queue is full, and additional error messages arrive, the oldest errors are lost. The previously read messages are not cleared from the queue; they remain in the queue until they are overwritten by a new error message.

The history error queue information can be accessed by pressing **System, Show Errors**. From this menu you can choose **Top Page, Last Page, Next Page, or Prev Page**, to switch between pages (if there are more than 17 error messages). To empty the queue, press **Clear Error Queue(s)**.

You can exit the error queue display by pressing either **ESC** or **Return**. Selecting a measurement under the **Measure** key will also exit the error queue display.

Error Message Format

Error messages will appear (in the format described below) in the Status/Info bar that appears at the bottom of the display. Generally the most recent message will appear, however there are occasions when an error message that has a higher priority will appear instead of the most recent one.

Error messages appear in the following format:

`<error number><error message><context-specific information><occurrences>`

`<error number>` - unique numeric identifier
(refer to the Error Message Descriptions section)

`<error message>` - generic description

`<context-specific information>` - (optional) additional information
about this particular occurrence of the error

`<occurrences>` - Many repetitive type errors are counted rather than
being individually logged. Occurrences (enclosed in

parentheses) show the number of times the error has occurred since the queue was last cleared.

SCPI Remote Interface Error Messages

Remote Error Queue

This queue is constructed in a linear first-in/first-out fashion. It can hold up to 30 error messages. As errors and events are detected, they are placed in the queue. Unlike the history error queue, errors in this queue are not overwritten by the latest incoming error messages. If the queue overflows, the last error in the queue is replaced with the error:

```
(-350) Queue overflow
```

When the queue overflows, the early errors remain in the queue, and the most recent error is discarded. Reading an error from the beginning of the queue removes that error from the queue, and opens a position at the end of the queue for a new error, if one is subsequently detected.

The queue overflow message remains in the queue until it is read. If errors continue to occur as the queue is read, the `Queue Overflow` message will be followed by as many of the new messages as will fit in the remaining queue space. If the queue fills again and another error occurs, another `Queue Overflow` message will be placed in the queue.

Querying the Error Queue

The `SYSTEM:ERROR[:NEXT]?` query is a request for the next entry from the instrument's error queue. The instrument responds to the query with the next error number in the queue and its description in the format:

```
<error number><error message><context-specific information>
```

The `<error number>` is a unique error identifier in the range from `-32768` to `32767`. A negative error value indicates a general SCPI programming error, while a positive error is more instrument specific. An error value of zero indicates that no error or event has occurred. Short descriptions of the standard error numbers are described in this section. The `<context-specific information>` section of the error message may contain information which allows you to determine the exact error and context. For example:

```
Invalid suffix; FREQuency:CENT 2.0E+5 dBmV
```

The maximum string length of the `<error message>` including the `<context-specific information>` is 255 characters. The `<error message>` will be sent exactly as indicated in this document, including case. In this example, the context-specific information was the `FREQ:CENT` command.

If there has been more than one error, the instrument will respond with the first one in the queue. Subsequent responses to `SYSTEM:ERROR?` will return errors until the queue is empty.

Clearing the Error Queue

The error queue will only be cleared upon:

- power up
- receipt of a *CLS command
- reading the last error from the queue

No Error

When all the errors have been read from the queue, further error queries will return:

(0) No error

This message indicates that the error queue contains no errors.

(Number)	Description
(0)	No error The queue is empty. Every error in the queue has been read or the queue was purposely cleared by power-on or *CLS.

Error Message Descriptions

Messages with No Numbers

Unnumbered messages are for operator information only and do not appear in any error queue.

Description

Acquiring Data...

A warning used when the data acquisition time is long enough to be noticeable.

AFUN not implemented

Awaiting Trigger, no AUTO Trig

Auto Trig is off and a trigger has not been detected for more than 4 seconds.

Break freq > FFT filter edge - clipping to %f kHz

Correction off

Data Acquisition FIFO_OVERFLOW, use AUTO
DataPacking..."

Data acquisition malfunction; need to use auto data packing to resolve.

GSM Hopping enabled, waiting for valid burst

When GSM hopping is enabled, this indicates that a valid GSM burst has not yet been found.

IF synthesizer unlocked

LAN external loopback test failed

This message will appear during boot-up if the instrument is not connected to a LAN cable. You can ignore the message if you are not using the LAN.

Please wait - Printing

Waiting for the print job to complete.

Settling Hardware...

A warning used when the hardware settling time is long enough to be noticeable.

Sync is RF ampl (not Training Seq). Bits not accurate.

Query Error Messages [–499 to –400]

An error number in the range [–499 to –400] indicates the instrument has found a problem when trying to respond to a SCPI query. The occurrence of any error in this class will cause the error query bit (bit 2) to be set in the event status register. If a query error occurs one of the following is true:

- An attempt is being made to read data from the output queue when no output is either present or pending.
- Data in the output queue has been lost.

Query Error Message Descriptions

(Number)	Description
(–440)	Query UNTERMINATED after indefinite response Indicates that a query was received in the same program message after a query requesting an indefinite response was executed (see IEEE 488.2, 6.3.7.5).
(–430)	Query DEADLOCKED Indicates that a condition causing a DEADLOCKED query error occurred (see IEEE 488.2, 6.3.1.7) (for example, both the input buffer and the output buffer are full and the device cannot continue).
(–420)	Query UNTERMINATED Indicates that a condition causing an UNTERMINATED query error occurred (see IEEE 488.2, 6.3.2.2) (for example, the device was addressed to talk and an incomplete program message was received).
(–410)	Query INTERRUPTED Indicates that a condition causing an INTERRUPTED query error occurred (see IEEE 488.2, 6.3.2.7) (for example, a query was followed by DAB or GET before a response was completely sent).
(–400)	Query Error This is a generic query error for devices that cannot detect more specific errors. The code indicates only that a query error as defined in IEEE 488.2, 11.5.1.1.7 and

6.3 has occurred.

Device-Specific Error Messages [-399 to -300]

An error number in the range [-399 to -300] indicates that the instrument has detected an error where some device operations did not properly complete, possibly due to an abnormal hardware or firmware condition. This is not a error in response to a SCPI query or command, or command execution. These errors are also used for self-test response errors. The occurrence of any error in this class will cause the device-specific error bit (bit 3) in the event status register to be set.

Device-Specific Error Message Descriptions

(Number)	Description
(-362)	Framing error in program message Indicates that a stop bit was not detected when data was received (for example, a baud rate mismatch).
(-361)	Parity error in program message Indicates that the parity bit was not correct when data was received (for example, an incorrect parity bit on a serial port).
(-360)	Communication error This is the generic communication error for devices that cannot detect more specific errors.
(-350)	Queue overflow This is a specific code entered into the queue in lieu of the code that caused the error. This message indicates that there is no more room in the queue and an error occurred but was not recorded.
(-340)	Calibration failed Indicates that the device has detected a failure during its calibration procedure.
(-330)	Self-test failed Indicates that the device has detected a failure during its self-test procedure.

If You Have a Problem
Error Message Descriptions

- (-321) Out of memory
Indicates that an internal operation needed more memory than was available.
If this occurs during a memory catalog display, it means the system did not have enough free RAM to prepare the catalog.
- (-320) Storage fault
Indicates that the firmware detected a fault when using data storage. This error is not an indication of physical damage or failure of any mass storage element.
- (-315) Configuration memory lost
Indicates that non-volatile configuration data saved by the device has been lost. The meaning of this error is device-dependent.
- (-314) Save/recall memory loss
Indicates that the non-volatile data saved by the *SAV? command has been lost.
- (-313) Calibration memory lost
Indicates that non-volatile calibration data has been lost.
- (-312) PUD memory lost
Indicates that the protected user data saved by the *PUD command has been lost.
- (-311) Memory error
Indicates that an error was detected in the device's memory.
- (-310) System error
Indicates that an error, termed "system error" by the device, has occurred.
- (-300) Device-specific error
This is a generic device-dependent error for devices that cannot detect more specific errors. The code indicates only that a device-dependent error as defined in IEEE 488.2, 11.5.1.1.6 has occurred.

Execution Error Messages [-299 to -200]

An error number in the range [-299 to -200] indicates that an error has been detected during instrument execution. The occurrence of any error in this class will cause the execution error bit (bit 4) in the event status register to be set. If this bit is set, one of the following events has occurred:

- A <program data> element following a header was evaluated by the device as outside of its legal input range or as otherwise inconsistent with the device capabilities.
- A valid program command could not be properly executed due to some device condition.

Execution errors will be reported by the device after rounding and expression evaluation operations have been completed. Rounding a numeric data element, for example, will not be reported as an execution error.

Execution Error Message Descriptions

(Number)	Description
(-294)	Incompatible type Indicates that the type or structure of a memory item is inadequate.
(-293)	Referenced name already exists A downloaded program attempted to define an element (a variable, constant, filename, etc.) that had already been defined.
(-292)	Referenced name does not exist A downloaded program attempted to access an undefined element (a variable, constant, filename, etc.)
(-291)	Out of memory A downloaded program required more memory than was available in the instrument.
(-286)	Program runtime error Indicates that a runtime error was detected in a downloaded program.
(-285)	Program syntax error Indicates that a syntax error appears within a downloaded program. The syntax used when parsing a downloaded program is device-specific.

- (-284) Program currently running
Indicates that certain operation related to programs may be illegal while the program is running (for example, deleting a running program may be illegal).
- (-283) Illegal variable name
Indicates that an attempt was made to reference a nonexistent variable.
- (-282) Illegal program name
Indicates that the name used to reference a program was invalid (for example, redefining an existing program, deleting a nonexistent program, or in general, referencing a nonexistent program).
- (-281) Cannot create program
Indicates that an attempt to create a program was unsuccessful. This may be due to insufficient memory.
- (-280) Program error
Indicates that a downloaded program-related execution error occurred. This error message is used when the device cannot detect more specific errors. The syntax used in a program and the mechanism for downloading a program is device-specific.
- (-278) Macro header not found
Indicates that a syntactically legal macro label in the *GMC? query could not be executed because the header was not previously defined.
- (-277) Macro redefinition not allowed
Indicates that the macro label defined in the *DMC command could not be executed because the macro label was already defined (see IEEE 488.2, 10.7.6.4).
- (-276) Macro recursion error
Indicates that a syntactically legal macro program data sequence could not be executed because the device found it to be recursive (see IEEE 488.2, 10.7.6.4).
- (-275) Macro definition too long
Indicates that a syntactically legal macro program data sequence could not be executed because the string or block contents were too long for the device to handle (see IEEE 488.2, 10.7.6.1).

- (-274) Macro parameter error
Indicates that the macro definition improperly used a macro parameter place holder (see IEEE 488.2, 10.7.3).
- (-273) Illegal macro label
Indicates that the macro label defined in the *DMC command was a legal string syntax, but could not be accepted by the device (see IEEE 488.2, 10.7.3 and 10.7.6.2) (for example, the label was too long, the same as a common command header, or contained invalid header syntax).
- (-272) Macro execution error
Indicates that a syntactically legal macro program data sequence could not be executed due to an error within the macro definition (see IEEE 488.2, 10.7.6.3).
- (-261) Math error in expression
Indicates that a syntactically legal expression program data element could not be executed due to a math error (for example, a divide-by-zero was attempted). The definition of a math error is device-specific.
- (-260) Expression error
Indicates that an expression data element related error occurred. This error message is used when the device cannot detect more specific errors.
- (-258) Media protected
Indicates that the device or user has attempted to write to a read-only memory subsystem (msus). The definition of a protected media is device-specific.
- (-257) File name error
Indicates that a legal program command or query could not be executed because a file name on the device media was in error (for example, an attempt was made to copy to a duplicate filename). The definition of what constitutes a file name error is device-specific.
- (-256) File name not found
Indicates that a legal program command or query could not be executed because the file name on the device media could not be found (for example, an attempt was made to read or copy a nonexistent file). The definition of what constitutes a file not being found is device-specific.

- (-255) Directory full
- Indicates that a legal program command or query could not be executed because the media directory was full. The definition of what constitutes a full media directory is device-specific.
- (-254) Media full
- Indicates that a legal program command or query could not be executed because the media was full (for example, there was no space left on the disk). The definition of what constitutes full media is device-specific.
- (-253) Corrupt media
- Indicates that a legal program command or query could not be executed because of corrupt media, for instance a bad disk or incorrect disk format. The definition of what constitutes corrupt media is device-specific.
- (-252) Missing media
- Indicates that a legal program command or query could not be executed because of missing media, for instance no disk in the disk drive. The definition of what constitutes missing media is device-specific.
- If this occurs during a memory catalog display, it means the default memory system could not be located. The instrument is likely not functioning properly. Report this error to the nearest Agilent Technologies Sales and Service office. Refer to the Sales and Service Office table in the user's guide for your instrument.
- (-250) Mass storage error
- Indicates that a mass storage error has occurred. This message is used when a device cannot detect more specific errors.
- (-241) Hardware missing
- Indicates that a legal program command or query could not be executed because of missing device hardware (for example, an option was not installed).
- (-240) Hardware error
- Indicates that a legal program command or query could not be executed because of a hardware problem in the device. The definition of what constitutes a hardware problem is completely device-specific. This error is used when the device cannot detect more specific errors.

- (-233) Invalid version
- Indicates that a legal program data element was parsed but could not be executed because the version of the data is incorrect to the device. This particular error is used when file or block data elements are recognized by the instrument, but cannot be executed for reasons of version incompatibility (for example, a non-supported file version or a non-supported instrument version).
- (-232) Invalid format
- Indicates that a legal program data element was parsed but could not be executed because the data format or structure is inappropriate (for example, when loading memory tables or when sending a `SYSTEM:SET` parameter for an unknown instrument).
- (-231) Data questionable
- Indicates that the measurement accuracy is questionable.
- (-230) Data corrupt or stale
- Possibly invalid data. A new reading was started but not completed since last access.
- (-226) Lists not same length
- Attempted to use LIST structure having individual LISTS of unequal length.
- (-225) Out of memory
- The device has insufficient memory to perform the requested operation.
- (-224) Illegal parameter value
- Used where exact value, from a list of possibilities, was expected.
- (-223) Too much data
- Indicates that a legal program data element of block, expression or string type was received that contained more data than the device could handle due to memory or related device-specific requirements.
- (-222) Data out of range
- Indicates that a legal program data element was parsed but could not be executed because the interpreted value was outside the legal range defined by the device (see IEEE 488.2 11.5.1.1.5).

- (-221) Settings conflict
Indicates that a legal program data element was parsed but could not be executed due to the current device state (see IEEE 488.2 11.5.1.1.5).
- (-220) Parameter error
Indicates that a program data element related error has occurred. This particular error message is used if the device cannot detect more specific errors.
- (-215) Arm deadlock
Indicates that the arm source for the initiation of a measurement is set to GET and a subsequent measurement query is received. The measurement cannot begin until a GET is received, but the GET would cause an INTERRUPTED error.
- (-214) Trigger deadlock
Indicates that a trigger source for the initiation of a measurement is set to GET and a subsequent measurement query is received. The measurement cannot begin until a GET is received, but the GET would cause an INTERRUPTED error.
- (-213) Init ignored
Indicates that a request for a measurement initiation was ignored as another measurement was already in progress.
- (-212) Arm ignored
Indicates that an arming signal was received and recognized by the device, but was ignored.
- (-211) Trigger ignored
Indicates that a GET, *TRG, or triggering signal was received and recognized by the device, but was ignored because of device timing considerations (for example, the device was not ready to respond).
- (-210) Trigger error
Indicates that a GET, *TRG, or a triggering signal could not be executed due to an error.
- (-202) Settings lost due to rtl
Indicates that a setting associated with a hard local control (see IEEE 488.2, 5.6.15) was lost when the device changed to LOCS from REMS or to LWLS from RWLS.

(-201) Invalid while in local

Indicates that a command is not executable while the device is in local mode due to a hard local control (see IEEE 488.2, 5.6.1.5) (for example, a device with a rotary switch receives a message which would change the switch's state, but the device is in local, so the message cannot be executed).

(-200) Execution Error

This is a generic syntax error for devices that cannot detect more specific errors. The code indicates only that an execution error as defined in IEEE 488.2, 11.5.1.1.5 has occurred.

Command Error Messages [-199 to -100]

An error number in the range [-199 to -100] indicates that an IEEE 488.2 syntax error has been detected by the instrument's parser. The occurrence of any error in this class will cause the command error bit (bit 5) in the event status register to be set. If this bit is set, one of the following events has occurred:

- An IEEE 488.2 syntax error has been detected by the parser. That is, a control-to-device message was received which is in violation of the IEEE 488.2 standard. Possible violations include a data element which violates device listening formats or whose type is unacceptable to the device.
- An unrecognized header was received. Unrecognized headers include incorrect device-specific headers and incorrect or unimplemented IEEE 488.2 common commands.

Command Error Message Descriptions

(Number)	Description
(-184)	Macro parameter error Indicates that a command inside the macro definition had the wrong number or type of parameters.
(-183)	Invalid inside macro definition Indicates that the program message unit sequence, sent with a *DDT or a *DMC command, is syntactically invalid (see IEEE 488.2, 10.7.6.3).
(-181)	Invalid outside macro definition Indicates that a macro parameter place holder (\$<number>) was encountered outside of a macro definition.
(-180)	Macro error This error is generated when using a macro or executing a macro. This error message is used if the device cannot detect a more specific error.
(-178)	Expression data not allowed A legal expression data was encountered, but was not allowed by the device at this point in parsing.
(-171)	Invalid expression The expression data element was invalid (see IEEE 488.2, 7.7.7.2) (for example, unmatched parentheses or an illegal character).

This error also occurs if a command is executed that is not valid for the current selected instrument mode. Use INSTRUMENT:SELEct to change the mode.

- (-170) Expression data error
This error is generated when parsing an expression data element. This particular error message is used if the device cannot detect a more specific error.
- (-168) Block data not allowed
A legal block data element was encountered, but not allowed by the device at this point in the parsing.
- (-161) Invalid block data
A block data element was expected, but was invalid (see IEEE 488.2, 7.7.6.2) (for example, an END message was received before the end length was satisfied).
- (-160) Block data error
This error is generated when parsing a block data element. This particular error message is used if the device cannot detect a more specific error.
- (-158) String data not allowed
A string data element was encountered, but not allowed by the device at this point in the parsing.
- (-151) Invalid string data
A string data element was expected, but was invalid (see IEEE 488.2, 7.7.5.2) (for example, an END message was received before the terminal quote character).
- (-150) String data error
This error is generated when parsing a string data element. This particular error message is used if the device cannot detect a more specific error.
- (-148) Character data not allowed
A legal character data element was encountered where prohibited by the device.
- (-144) Character data too long
The character data element contains more than twelve characters (see IEEE 488.2, 7.7.1.4).

- (-141) Invalid character data
Either the character data element contains an invalid character or the particular element received is not valid for the header.
- (-140) Character data error
This error is generated when parsing a character data element. This particular error message is used if the device cannot detect a more specific error.
- (-138) Suffix not allowed
A suffix was encountered after a numeric element which does not allow suffixes.
- (-134) Suffix too long
The suffix contained more than twelve characters (see IEEE 488.2, 7.7.3.4).
- (-131) Invalid suffix
The suffix does not follow the syntax described in IEEE 488.2, 7.7.3.2, or the suffix is inappropriate for this device.
- (-130) Suffix error
This error is generated when parsing a suffix. This particular error message is used if the device cannot detect a more specific error.
- (-128) Numeric data not allowed
A legal numeric data element was received, but the device does not accept one in this position for the header.
- (-124) Too many digits
The mantissa of a decimal-numeric data element contained more than 255 digits excluding leading zeros (see IEEE 488.2, 7.7.2.4.1).
- (-123) Exponent too large
The magnitude of an exponent was greater than 32000 (see IEEE 488.2, 7.7.2.4.1).
- (-121) Invalid character in number
An invalid character for the data type being parsed was encountered (for example, an alpha in a decimal numeric or a “9” in octal data).

- (-120) Numeric data error
This error is generated when parsing a data element which appears to be numeric, including non-decimal numeric types. This particular error message is used if the device cannot detect a more specific error.
- (-114) Header suffix out of range
The value of a header suffix attached to a program mnemonic makes the header invalid.
- (-113) Undefined header
The header is syntactically correct, but it is undefined for this specific device (for example, *XYZ is not defined for any device).
The command (header) may not be valid for the current instrument mode. Use INST:SElect to change the mode.
The command may not be valid for the current (specified) measurement. (e.g. CALC:WAV:MARK:MAX is not valid because the waveform measurement does not use the marker maximum command.)
- (-112) Program mnemonic too long
The header contains more than twelve characters (see IEEE 488.2, 7.6.1.4.1).
- (-111) Header separator error
A character which is not a legal header separator was encountered while parsing the header.
- (-110) Command header error
An error was detected in the header. This message is used when the device cannot detect more specific errors.
- (-109) Missing parameter
Fewer parameters were received than required for the header (for example, the *ESE common command requires one parameter, so receiving *ESE is not allowed).
- (-108) Parameter not allowed
More parameters were received than expected for the header (for example, the *ESE common command only accepts one parameter, so receiving *ESE 0,1 is not allowed).

If You Have a Problem
Error Message Descriptions

- (-105) GET not allowed
A Group Execute Trigger was received within a program message (see IEEE 488.2, 7.7). Correct the GPIB controller program so that the GET does not occur within a line of GPIB program code.
- (-104) Data type error
The parser recognized a data element that is not allowed (for example, numeric or string data was expected, but block data was encountered).
- (-103) Invalid separator
The parser was expecting a separator and encountered an illegal character (for example, the semicolon was omitted after a program message unit).
- (-102) Syntax error
An unrecognized command or data type was encountered (for example, a string was received when the device does not accept strings).
- (-101) Invalid character
A syntactic command contains a character which is invalid for that type (for example, a header containing an ampersand, SETUP&).
- (-100) Command error
This is a generic syntax error for devices that cannot detect more specific errors. The code indicates only that a command error as defined in IEEE 488.2, 11.5.1.1.4 has occurred.

Instrument-Specific Error Messages [positive numbers]

Some instrument-specific error messages use the existing negative or “generic” SCPI error numbers with the addition of device-dependent or instrument-specific information following the semicolon in the error message. A positive error number indicates that the instrument has detected an error within the GPIB system, within the instrument firmware or hardware, during the transfer of block data, or during calibration.

An error number in the positive range indicates that the instrument has detected an error relating to the core operation [1 to 99], or to a personality loaded into the instrument, GSM [100 to 199] or CDMA [200 to 299].

Core-Specific Error Messages [1 to 99]

An error number in the range [1 to 99] indicates the instrument has detected an error relating to the core functionality of the instrument.

Core-Specific Error Message Descriptions

(Number)	Description
(1)	Synthesizer unlocked The A19 synthesizer assembly has lost phase lock. Suspect a problem with the A19 hardware or absence of 10 MHz from the A18 reference assembly.
(2)	Frequency reference unlocked The 100 MHz VCXO on the A18 reference assembly is no longer phase locked. Possible causes are; a faulty internal OCXO, the external reference bad or missing, or faulty phase lock circuitry on the A18 reference assembly.
(3)	Third LO unlocked The third LO on the A12 analog IF assembly has lost phase lock. Possible causes are; a faulty A12 analog IF assembly, or a missing 10 MHz from the A18 reference assembly.
(4)	Cal oscillator unlocked The 42.8 MHz calibrator oscillator on the A12 analog IF assembly is unlocked.

If You Have a Problem
Error Message Descriptions

- (5) Analog IF sample rate osc unlocked
The 30 MHz sample rate oscillator on the A12 analog IF assembly is unlocked.
- (6) Even second clock failing
The even second clock is unlocked.
- (7) No application file
- (8) Catalog incomplete
- (9) Application not licensed
License key “word” is not entered into instrument memory.
- (10) Application not installed
Measurement application could not be found.
- (11) Invalid application file
Caused by an invalid personality file.
- (12) Application load failed
Measurement application could not load.
- (13) Invalid trace number
Caused by an invalid trace number. Some measurements only have 1 or 2 valid traces, rather than the indicated 4.
- (14) Trace data not ready
This may be caused by sending a command that asks for trace data from a measurement that has not finished calculating, or from a measurement that is not currently active (running).
- (15) Measurement data not available
This may be caused by sending a command that asks for data from a measurement that is not currently active (running).

- (16) Input Overload Decrease max total power in input.
Excessive input power has been detected which will cause the ADC to clip the signal. Reduce the signal level, change the attenuator/max total power setting (under Input menu), or press Restart if the RF Input Range is Auto.
- (17) Data Acquisition forcing SHORT packing
The data acquisition rate is too high to use longer word packing.
- (18) Command not implemented
The requested command is not implemented.
- (19) Function not implemented
The requested function is not implemented.
- (20) Signal exceeds maximum allowable power - Reduce input power
Excessive input power has been detected which will cause the ADC to clip the signal.
- (21) Memory Allocation FAILURE
- (22) Memory limit caused Data Acquisition to be truncated
Caused by a Memory Allocation failure. The measurement limited the acquisition time in order to complete the measurement.
- (23) Setup INVALID
The parameters chosen create a measurement request that is impossible to complete, often due to memory limitations.
- (24) External reference missing
The external frequency reference signal either is missing, has too low an amplitude, or does not match the frequency value previously entered into the instrument memory by the operator.
- (25) Even Second Clock missing
The even second clock signal supplied from the base station is missing. Check the external trigger input connection where the even second clock signal is fed into the instrument.

If You Have a Problem
Error Message Descriptions

- (26) Oven temp low
The oven-controlled crystal oscillator is not at the desired operating temperature.
- (27) Alignment Needed
The Auto Align routine needs to be run. At least 24 hours has passed since the last full alignment, or the temperature has changed 6° C.
- (28) Printer failure
Check for proper printer operation.
- (29) Printer not available
The requested printer is not available. Check for proper printer hookup.
- (30) Printer out of paper
Put paper in the printer.
- (31) Data Acquisition TIMEOUT, repairs underway..."
Hardware malfunction, data acquisition subsystem.
- (32) ADC Alignment Failure
One or more built-in alignment tests have failed.
- (33) IF Alignment Failure
One or more built-in alignment tests have failed.
- (34) RF Alignment Failure
One or more built-in alignment tests have failed.
- (35) System Alignment Failure
One or more built-in alignment tests have failed.

GSM-Specific Error Messages [100 to 199]

An error number in the range [100 to 199] indicates the instrument has detected an error relating to the GSM personality.

GSM-Specific Error Message Descriptions

(Number)	Description
(100)	Not enough data to fit into GSM mask An attempt to position a GSM trace into the mask, when not enough data was present. Try using the Restart key to clear the problem. This can be caused by a bad GSM burst, or the RF Sync Delay set too far.
(101)	GSM burst out of limits The GSM signal did not fit into the mask in the Power vs. Time measurement.
(102)	Insufficient pre-Trig for demod - decrease Trig Delay
(103)	Incorrect RBW for demod - change RBW
(104)	Invalid GSM burst timing A GSM-like burst was acquired, but it's timing is not valid. Ensure the correct Burst Type has been selected.
(105)	Valid GSM burst not found In a GSM measurement, data was acquired but a GSM burst was not found.
(106)	Cannot synchronize frame trigger Cannot synchronize the frame trigger to the even second clock.
(107)	Dynamic range not optimum - set AUTO RF input
(108)	Cannot synchronize to RF amplitude (burst error)
(109)	GSM RF sync delay is out of range Change RF Sync Delay.

If You Have a Problem
Error Message Descriptions

- (110) Sync word not found
In a GSM measurement using demodulation, the training sequence code (sync word) could not be found.
- (111) Signal too noisy
In a GSM measurement, indicates that a burst could not be found in a signal that appears noisy.
- (112) Incorrect trigger holdoff - set to 0 sec
- (113) SCPI marker query not available in GSM Rise&Fall
- (114) GSM Pwr Meas requires trig delay < -50us.
Delay set to -50us

CDMA-Specific Error Messages [200 to 299]

An error number in the range [200 to 299] indicates the instrument has detected an error relating to the CDMA personality.

CDMA-Specific Error Message Descriptions

(Number)	Description
(200)	Signal near noise floor - Power accuracy degraded
(201)	Signal exceeds maximum allowable power - Reduce input power
(202)	Input overload Excessive input power has been detected which will cause the ADC to clip the signal. Reduce the signal level, change the attenuator/max total power setting (under Input menu), or press Restart if the RF Input Range is Auto.
(203)	Channel center frequency outside device's transmit band
(205)	No power at carrier frequency No power was detected as a CW or a modulated signal.
(206)	Cannot correlate to input signal A correlation failure with the pilot CDMA channel occurred during synchronous demodulation.

NADC-Specific Error Messages [300 to 399]

An error number in the range [300 to 399] indicates the instrument has detected an error relating to the NADC personality.

NADC-Specific Error Message Descriptions

(Number)	Description
(300)	Sync word not found In an EVM measurement, the sync word is not found and the synchronization cannot be established when Sync Word is selected in the Burst Sync menu.
(301)	Valid NADC burst not found A valid NADC burst is not found when the Device is MS.
(302)	Signal too noisy The valid EVM measurement cannot be performed, because the input signal is too noisy.
(303)	Burst Delay exceeds 2 ms limit for EVM In an EVM measurement, the Burst Delay value must be less than 2 ms.

PDC-Specific Error Messages [400 to 499]

An error number in the range [400 to 499] indicates the instrument has detected an error relating to the PDC personality.

PDC-Specific Error Message Descriptions

(Number)	Description
(400)	Sync word not found In an EVM measurement, the sync word is not found and the synchronization cannot be established when Sync Word is selected in the Burst Sync menu.
(401)	Valid PDC burst not found A valid PDC burst is not found when the Device is MS.
(402)	Signal too noisy The valid EVM measurement cannot be performed, because the input signal is too noisy.
(412)	Burst Delay exceeds 2 ms limit for EVM In an EVM measurement, the Burst Delay value must be less than 2 ms.

Warranty Information

Warranty

This Agilent Technologies instrument product is warranted against defects in material and workmanship for a period of three years from date of shipment. During the warranty period, Agilent Technologies will, at its option, either repair or replace products that prove to be defective.

For warranty service or repair, this product must be returned to a service facility designated by Agilent Technologies. Buyer shall prepay shipping charges to Agilent Technologies and Agilent Technologies shall pay shipping charges to return the product to Buyer. However, Buyer shall pay all shipping charges, duties, and taxes for products returned to Agilent Technologies from another country.

Agilent Technologies warrants that its software and firmware designated by Agilent Technologies for use with an instrument will execute its programming instructions when properly installed on that instrument. Agilent Technologies does not warrant that the operation of the instrument, or software, or firmware will be uninterrupted or error-free.

LIMITATION OF WARRANTY

The foregoing warranty shall not apply to defects resulting from improper or inadequate maintenance by Buyer, Buyer-supplied software or interfacing, unauthorized modification or misuse, operation outside of the environmental specifications for the product, or improper site preparation or maintenance.

NO OTHER WARRANTY IS EXPRESSED OR IMPLIED. AGILENT TECHNOLOGIES SPECIFICALLY DISCLAIMS THE IMPLIED WARRANTIES OF MERCHANTABILITY AND FITNESS FOR A PARTICULAR PURPOSE.

EXCLUSIVE REMEDIES

THE REMEDIES PROVIDED HEREIN ARE BUYER'S SOLE AND EXCLUSIVE REMEDIES. AGILENT TECHNOLOGIES SHALL NOT BE LIABLE FOR ANY DIRECT, INDIRECT, SPECIAL, INCIDENTAL, OR CONSEQUENTIAL DAMAGES, WHETHER BASED ON CONTRACT, TORT, OR ANY OTHER LEGAL THEORY.

Returning Your Instrument to Agilent Technologies

If you are returning your transmitter tester to Agilent Technologies for servicing, fill out and attach a blue repair tag to the instrument. Repair tags are located at the end of this chapter.

Include as much information as possible about the problem. Record any error messages that appeared on the display and include performance test results or any other specific data on the performance of the instrument.

Ship the instrument in the original factory packaging materials, if they are available. If not, use similar packaging to properly protect the instrument.

Return the instrument to the nearest Agilent Technologies sales and service office. A list of sales and service offices follows.

Table 6-1 Agilent Technologies Sales and Service Offices

UNITED STATES		
Instrument Support Center Agilent Technologies (800) 403-0801		
EUROPEAN FIELD OPERATIONS		
Headquarters Agilent Technologies S.A. 150, Route du Nant-d'Avril 1217 Meyrin 2/ Geneva Switzerland (41 22) 780.8111	France Agilent Technologies France 1 Avenue Du Canada Zone D'Activite De Courtaboeuf F-91947 Les Ulis Cedex France (33 1) 69 82 60 60	Germany Agilent Technologies GmbH Hewlett-Packard Strasse 61352 Bad Homburg v.d.H Germany (49 6172) 16-0
Great Britain Agilent Technologies Ltd. Eskdale Road, Winnersh Triangle Wokingham, Berkshire RG41 5DZ England (44 118) 9696622		
INTERCON FIELD OPERATIONS		
Headquarters Agilent Technologies Company 3495 Deer Creek Rd. Palo Alto, CA 94304-1316 USA (415) 857-5027	Australia Agilent Technologies Australia Ltd. 31-41 Joseph Street Blackburn, Victoria 3130 (61 3) 895-2895	Canada Agilent Technologies (Canada) Ltd. 17500 South Service Road Trans-Canada Highway Kirkland, Quebec H9J 2X8 Canada (514) 697-4232
Japan Agilent Technologies Japan, Ltd. 9-1 Takakura-Cho, Hachioji Tokyo 192, Japan (81 426) 60-2111	Singapore Agilent Technologies Singapore (Pte.) Ltd. 150 Beach Road #29-00 Gateway West Singapore 0718 (65) 291-9088	Taiwan Agilent Technologies Taiwan 8th Floor, H-P Building 337 Fu Hsing North Road Taipei, Taiwan (886 2) 712-0404
China China Agilent Technologies 38 Bei San Huan X1 Road Shuang Yu Shu Hai Dian District Beijing, China (86 1) 256-6888		

Blue Repair Tag goes here

If You Have a Problem
Blue Repair Tag goes here

Options and Measurement Personalities

Option BAH

GSM measurement personality. Provides GSM transmitter measurements including power vs. time, phase and frequency error, and output RF spectrum. Includes GSM Measurement Guide and Programming Commands manual.

Option BAC

cdmaOne measurement personality. Provides IS-95 transmitter measurements, including channel power, modulation accuracy (rho), code domain power, ACPR, and spur close. Includes cdmaOne Measurement Guide and cdmaOne Programming Commands manual.

Option BAE

NADC/PDC measurement personalities. Provides NADC/PDC transmitter measurements, including ACP and error vector magnitude. Includes NADC/PDC Measurement Guide and NADC/PDC Programming Commands manual.

Option HN1

iDEN measurement personality. Provides iDEN transmitter measurements, including ACP, bit error rate, and occupied bandwidth. Includes iDEN Measurement Guide (which contains iDEN programming commands).

Option BAF

W-CDMA measurement personality. Provides W-CDMA transmitter measurements, including channel power, ACPR, Power Stat CCDF, QPSK EVM. Includes W-CDMA Measurement Guide and W-CDMA Programming Commands manual.

Option B78

cdma2000 measurement personality. Provides cdma2000 transmitter measurements, including channel power, ACPR, Power Stat CCDF, QPSK EVM, and modulation accuracy (rho). Includes cdma2000 Measurement Guide and cdma2000 Programming Commands manual.

Option 300

Adds 321.4 MHz IF Output to the rear panel.

Option 0B1

Adds an additional copy of the standard manual set, which includes the User's Guide, the Programming Guide, and Specifications manuals. Current documentation is available on the VSA web page at www.agilent.com/find/vsa.

Documentation
User's Guide
Programmer's Guide
Specifications

Option 0BV

Adds component level service documentation.

Documentation
Component Level Information

Option 0BW

Adds assembly level service documentation. This option includes:

Documentation
Service Guide
Specifications

Option 1CM

Rack mount kit. Includes rack mount flanges and hardware. Used to rack mount instruments without front handles. Available as P/N 5063-9215.

Option 1CN

Handle kit. Available as P/N 5063-9228.

Option 1CP

Rack mount with handle kit. Rack mounts instrument which has front handles attached. Available as P/N 5063-9222.

Option 1CR

Rack slide kit. Available as P/N E4406 -60115

VSA Transmitter Tester Measurement Personalities Retrofit

Optional measurement personalities can be retrofitted. To obtain information on available personalities, updating firmware, and general product information contact the following URL:

URL to contact to obtain product update information
--

www.agilent.com/find/vsa/
--

Further information on installing optional measurement personalities can be found in “[Installing Optional Measurement Personalities](#)” on [page 38](#).

Accessories

AC Probe

The Agilent 85024A high frequency probe performs in-circuit measurements without adversely loading the circuit under test. The probe has an input capacitance of 0.7 pF shunted by 1 M Ω of resistance and operates over a frequency range of 300 kHz to 3 GHz. High probe sensitivity and low distortion levels allow measurements to be made while taking advantage of the full dynamic range of the instrument.

The Agilent 41800A low frequency probe has a low input capacitance and a frequency range of 5 Hz to 500 MHz.

Broadband Preamplifiers and Power Amplifiers

Preamplifiers and power amplifiers can be used with your instrument to enhance measurements of very low-level signals.

- The Agilent 10855A preamplifier provides a minimum of 22 dB gain from 2 MHz to 1300 MHz. (Power is supplied by the transmitter tester's probe power output.)
- The Agilent 8447D preamplifier provides a minimum of 25 dB gain from 100 kHz to 1.3 GHz.
- The Agilent 87405A preamplifier provides a minimum of 22 dB gain from 10 MHz to 3 GHz. (Power is supplied by the instrument probe power output.)

GPIB Cable

The Agilent 10833 GPIB cables interconnect GPIB devices and are available in four different lengths. GPIB cables are used to connect printers and controllers to an instrument.

Parallel Interface Cable

The HP 92284A parallel interface cable is a 36-pin to 25-pin male-to-male 2 meter cable used to connect supported printers to an instrument.

Printer

The DeskJet personal printers provide black and white or color printing for another form of permanent records of your test results. The HP LaserJet series printers are also compatible.

RS-232 Cables

Model Number	Description
HP 24542G	3 meter 9-pin (f) to 25-pin (m) RS-232 cable. Can be used with HP DeskJet printers, HP LaserJet Series printers, and PCs with 25-pin (f) RS-232 connectors.
HP 24542U	3-meter 9-pin (f) to 9-pin (f) RS-232 cable for serial 9-pin PC connection to an instrument.
HP C2932A	9-pin (m) to 9-pin (f) cable for RS-232 connection. The modem cable required is HP 24542M 9-pin (f) to 25-pin (m), and the PC cable is HP 24542U.

N2714A Calibration and Adjustment Software

This software automates all the tests needed to verify instrument performance, make adjustments, and troubleshoot. The software runs on a PC platform using Windows® 95/98 or NT 4.0, and uses the Agilent Test Management Environment to help minimize calibration run time and operator involvement.

Support Documentation

The following materials are available for purchase from Agilent Technologies in the formats indicated.

Table 7-1

Part Number	Description	Notes
E4406-90082	User's Guide	Includes E4406-90057 and E4406-90085
E4406-90086	Programming Guide	Does not include commands for the optional measurement personalities
E4406-90100	cdmaOne Measurement Guide	BAC Option manuals
E4406-90102	cdmaOne Programming Commands	
E4406-90101	GSM Measurement Guide	BAH Option manuals
E4406-90103	GSM Programming Commands	
E4406-90059	NADC, PDC Measurement Guide	BAE Option manuals
E4406-90060	NADC, PDC Programming Commands	
E4406-90087	iDEN Measurement Guide (includes programming commands)	HN1 Option manual
E4406-90088	W-CDMA Measurement Guide	BAF Option manuals
E4406-90089	W-CDMA Programming Commands	
E4406-90105	cdma2000 Measurement Guide	B78 Option manuals
E4406-90106	cdma2000 Programming Commands	
E4406-90085	Specifications	Includes specifications for all optional measurement personalities
E4406-90015	Service Guide	Includes assembly level service information
E4406-90057	Documentation CD	Includes VXI driver and programming examples
E4406-90017	CLIP Set	Component level information packets: pc board schematics, parts lists & component location diagrams

Numerics

- 50 MHz Amptd key, [127](#)
- 50 MHz Ref key, [77](#)

A

- AC probe, [209](#)
- Accessories, [209](#)
- accessories
 - AC probe, [209](#)
 - broadband preamplifiers, [209](#)
 - cal and adj software, [210](#)
 - GPIB cable, [209](#)
 - parallel cable, [209](#)
 - parallel interface cable, [209](#)
 - printer, [209](#)
 - printers, [209](#)
 - RS-232 cable, [210](#)
- active function area, [35](#)
- active license key, [39](#)
 - how to locate, [39](#)
- ADC Dither key
 - spectrum measurement, [96](#)
 - waveform measurement, [102](#)
- ADC Range key
 - spectrum measurement, [95](#)
 - waveform measurement, [102](#)
- adjustment, [65](#)
- adjustment keys, [65](#)
- adjustment software, [210](#)
- Advanced menu
 - spectrum, [94](#)
 - waveform, [102](#)
- Align 50 MHz Reference key, [66](#)
- Align ADC key, [66](#)
- Align All Now key, [66](#)
- Align Current IF Flatness key, [67](#)
- Align Current Sysgain key, [67](#)
- Align IF key, [66](#)
- Align RF key, [66](#)
- Align Subsystems key, [66](#)
- alignment keys, [65](#)
- Alignments key, [65](#)
- Alpha Editor key, [72](#)
- amplifiers, [209](#)
- amplitude accuracy, [143](#)
 - test description, [143](#)
- amplitude Y scale
 - scale coupling, [109](#)
- annunciator bar, [37](#)
- annunciators, [169](#)
- application notes, [19](#)
- attenuator accuracy, [148](#)
 - test description, [148](#)
- Auto Align key, [66](#)
- Auto Trig key, [79](#)
- average noise level, [151](#)
 - test description, [151](#)

Averaging menu

- Avg Mode key, [85](#)
- Avg Number key, [85](#)
- Avg Type key, [85](#)

B

- Band Pwr key, [90](#)
- Basic key, [82](#)
- basic mode
 - selecting, [76](#)
- broadband preamplifiers, [209](#)
- bus configuration keys, [62](#)

C

- cable
 - GPIB, [209](#)
 - parallel interface, [209](#)
 - RS-232, [210](#)
- cables
 - RS-232, [42](#)
- cal and adj software, [210](#)
- calibration, [65](#)
- calibration keys, [65](#)
- calibration software, [210](#)
- cdmaOne
 - selecting, [76](#)
- channel
 - selecting the, [80](#)
- channel power, [106](#)
 - advanced menu, [106](#)
 - amplitude Y scale
 - reference position, [109](#)
 - reference value, [109](#)
 - scale/div, [109](#)
 - channel bandwidth, [106](#)
 - channel power span, [108](#)
 - integration bandwidth, [108](#)
 - power spectral density, [106](#)
 - sweep time, [109](#)
 - time record length, [106](#)
- Choose Option key, [40](#)
- computers
 - RS-232 cables, [42](#)
- configuring I/O, [62](#)
- context dependency map
 - mode, [21](#)
- context dependency maps
 - front panel, [24](#)
 - measure, [23](#)
 - mode, [22](#)
- Corrections key, [67](#)
- Corrections Off error
 - annunciator, [36](#), [169](#)

D

- DANL, [151](#)

- test description, [151](#), [154](#)
- data entry, [29](#)
 - numeric keys, [29](#)
- Data Packing
 - spectrum measurement, [96](#)
- Data Packing key
 - waveform measurement, [102](#)
- DC probes
 - use of, [209](#)
- Decimation
 - spectrum measurement, [96](#)
- Decimation key
 - waveform measurement, [102](#)
- deleting an
 - application/personality, [38](#)
- Delta key, [90](#)
- DeskJet printers, [209](#)
- Diagnostics key, [70](#)
- display
 - error annunciators, [169](#)
- display average noise level
 - test description, [151](#)
- displayed average noise level, [151](#)
- documentation
 - option, [17](#)
 - transmitter tester, [17](#)

E

- editing text, [72](#)
- equipment
 - functional testing, [135](#), [136](#)
 - testing, [136](#)
- Error annunciator, [36](#), [169](#)
- error annunciators, [169](#)
- error messages
 - front panel error queue, [169](#)
 - front panel error/status bar, [169](#)
- error queue, [170](#), [172](#)
- errors
 - 0, [173](#)
 - 1 to 99, [191](#)
 - 100 to 199, [195](#)
 - 199 to -100, [186](#)
 - 200 to 299, [197](#)
 - 300 to 399, [198](#)
 - 399 to -300, [177](#)
 - 400 to 499, [199](#)
 - 499 to -400, [175](#), [179](#)
 - corrections off, [37](#)
 - descriptions, [174](#)
 - instrument specific, [191](#)
 - keys, [69](#)
 - not in list, [174](#)
 - oven cold, [37](#)
 - querying the error queue, [172](#)
 - SCPI remote interface error
 - queue, [172](#)

- troubleshooting front panel, 166
- unlock, 37
- with no number, 174
- ESC key, 26
- Ethernet Addr key, 62
- ethernet key, 62
- Even Second error annunciator, 37, 170
- Exit Core Firmware, 38
- exponential averaging, 85
- Ext Front key, 86
- Ext Rear key, 86
- external reference, 37
 - using an, 64
- External Reference error annunciator, 36, 169
- F**
- FFT Length key, 95
- FFT Size menu, 95
- FFT Window key, 95
- file features, 71
- Firmware Revision key, 70
- flatness, 138
 - frequency response, 138
 - test description, 138
- floppy disk drive, 29
- Frame Timer key, 79
- Free Run key, 86
- Freq Ref key, 64
- frequency
 - selecting the, 80
- frequency response, 138
 - flatness, 138
 - test description, 138
- FREQUENCY/channel key, 80
- front panel key menu maps, 21
- front panel keys, 25
- Front Panel Test, 131
- Function key, 90
- functional test descriptions, 137
- functional testing
 - before starting, 135
 - equipment, 135, 136
 - getting started, 135
 - introduction, 134
 - performance verification, 134
 - required test equipment, 136
 - test descriptions, 137
 - test equipment, 135, 136
 - test list, 137
 - test setups, 135
 - warmup times, 135
- G**
- GPIB Address key, 62
- GPIB cable, 209
- GPIB keys, 62
- GSM
 - selecting, 76
- H**
- hardware configuration keys, 65
- Help key, 31
- Home key, 30
- Host ID key, 70
- Host Name key, 62
- HP 13242G Cable, 43
- HP 24542G/H Cable, 43
- HP 24542M Cable, 44
- HP 24542U Cable, 42, 45, 46
- HP 5181-6639 Adapter, 46, 47
- HP 5181-6640 Adapter, 45, 46
- HP 5181-6641 Adapter, 45, 46
- HP 5181-6642 Adapter, 45, 47
- HP 92219J Cable, 43
- HP C2913A/C2914A Cable, 44
- HP F1047-80002 Cable, 42, 46, 47
- HP LaserJet printers, 209
- HP sales and service offices, 202
- HP-IB cable, 209
- I**
- I/O
 - configuring, 62
- I/Q Input Z key, 78
- I/Q waveform
 - spectrum view, 97
- I/Q Waveform key, 87
- I/Q waveform window
 - waveform view, 104
- IF Align Signal menu
 - Signal Amptd key, 78
 - Signal Rate key, 78
 - Signal Type key, 78
- IF Flatness
 - advanced spectrum feature, 96
- Input Atten key, 78
- input attenuation, 78
- input attenuator accuracy, 148
 - test description, 148
- Input menu
 - 50 MHz Ref key, 77
 - I/Q key, 77
 - Port key, 77
 - RF key, 77
- Input/Output keys, 62
- inputs
 - external trigger, 31
 - I and Q, 31
- Install Now key, 40
- installing measurement personalities, 38
- instrument-specific errors
 - positive numbers, 191
- IP Address key, 62
- IP address keys, 62
- K**
- key access path, 53
- key access table, 53
- key entries, 53
- key menu maps, 21
- keyboard
 - attaching external, 33
- L**
- LAN keys, 62
- LAN-TP connector, 34
- Length Ctrl key, 95
- Length key, 95
- Line key, 86
- line power input, 33
- Load State key, 71
- loading an
 - application/personality, 38
- local
 - placing instrument in, 70
- M**
- making basic measurements, 82
- Marker key, 89
- Marker menu
 - Band Pwr key, 90
 - Delta key, 90
 - Function key, 90
 - Noise key, 90
 - Select key, 90
 - Shape key, 90
- Max Total Pwr key, 78
- Meas Control key, 84
- Measure softkey, 84
- measurement
 - channel power, 108
- measurement bar, 36
- measurement personalities
 - retrofit, 207
- measurements
 - basic, 82
 - how to make, 82
- menu map, 21
- Min Pts in RBW key, 95
- mode
 - basic, 82
 - selecting, 76
 - setup, 77
- Mouse Adapter (typical), 44

N

N2714A cal and adj software, 210
Navigation keys, 30
Next Window key, 30
Noise key, 90
noise level, 151
 test description, 151
noise, display average
 test description, 151
noise, displayed average, 151
noise, phase, 154
 test description, 154
Normal key, 89

O

on/off switch, 31
Options
 OB1 (standard manual set), 207
 OBV (service guide), 207
 OBW (service guide and specifications), 207
 1CM (rack mount kit), 207
 1CN (handle kit), 207
 1CP (rack mount and handle kit), 207
 1CR (rack slide kit), 207
 B78 (cdma 2000), 206
 BAC (cdmaOne), 206
 BAE (NADC/PDC), 206
 BAF (W-CDMA), 206
 BAH (GSM), 206
 HN1 (iDEN), 206

P

parallel connector, 34
parallel interface cable, 209
pc cables for RS-232, 42
personality
 selecting, 76
phase noise, 154
power amplifiers, 209
Pre-ADC BPF key
 spectrum measurement, 94
 waveform measurement, 102
preamplifiers, 209
Pre-FFT BW key, 94
Pre-FFT Fltr key, 94
preset
 factory default, 76
Preset key, 83
Print Location key, 73
Print Setup key, 73
Print Type key, 73
printer, 209
Printer key, 73
printers, 209

RS-232 cables, 42
printing, 73
probe power, 28
probes
 AC and DC, 209
problems
 error messages, 166
 feature cannot be accessed, 166
 LAN connection, 166
 power-on, 166

R

RBW Filter key, 102
Rear panel connection keys, 62
rear panel connections, 32
Ref Position key, 87
Ref Value key, 87
Reference key, 64
repair, returning your instrument, 201
repeat averaging, 85
required test equipment
 functional testing, 136
 testing, 136
Res BW key
 spectrum measurement, 94
 waveform measurement, 102
residual, 160
 test description, 160
residual responses, 160
 test description, 160
responses, residual, 160
 test description, 160
Restore Align Defaults key, 67
Restore Meas Defaults key, 84
Restore Sys Defaults key, 69
Return key, 30
returning your instrument, 201
returning your instrument to Hewlett-Packard, 201
RF Burst key, 86
RF Envelope key, 87, 104
RF input, 29
RPG knob, 29
RS-232 cable, 210
RS-232 cables, 42
RS-232 connector, 34

S

safety
 installing instrument, 48
 using instrument, 49
safety symbols, 49
sales and service offices, 202
save features, 71
Save State key, 71
Scale/Coupling key, 87

Scale/Div key, 87
SCSI connection, 33
Search key, 90
selecting a printer, 73
Sensors key, 129
Serial Number key, 70
Service key, 120
Service menu
 50 MHz Amptd, 120
 Front Panel Keys, 120
 Power vs Time, 120
 Sensors, 120
 Spectrum, 120
 Timebase, 120
 Waveform, 120
service mode
 selecting, 76
service password, 70
setups
 functional testing, 135
Shape key, 90
shipment
 verification list, 17
Show Errors key, 69, 170
Show System key, 70
SICL server keys, 62
softkeys
 greyed-out keys, 25
 highlighted keys, 25
 menu keys, 25
 numeric, 25
 numeric+toggle, 25
 toggle, 25
software, cal and adj, 210
Span key, 87
 spectrum measurement, 94
SPAN/X Scale menu, 87
Spectrum (Frequency Domain) key, 91
spectrum measurement
 making the measurement, 91
 method, 91
 results, 91
spectrum window, 87, 97
status keys, 65
status/info bar, 37
Sweep Time key, 87, 102
Sync Source menu, 80
system keys, 52

T

tab keys, 30
telnet key, 62
test descriptions, 137
 amplitude accuracy, 143
 attenuator accuracy, 148
 average noise level, 151

DANL, [151](#)
displayed average noise level,
 [151](#)
frequency response, [138](#)
input attenuator accuracy, [148](#)
noise displayed average, [151](#)
noise, phase, [154](#)
phase noise, [154](#)
residual, [160](#)
residual responses, [160](#)
responses, residual, [160](#)
test equipment
 functional testing, [135](#), [136](#)
 testing, [136](#)
warm-up times, [135](#)
test list
 functional testing, [137](#)
 testing, [137](#)
testing
 required test equipment, [136](#)
 test equipment, [136](#)
text
 how to enter, [72](#)
Time Corr key, [67](#)
Timebase Frequency key, [125](#)
Trace Display key, [87](#)
Trigger key, [79](#)
Trigger menu
 Auto Trig key, [79](#)
 Delay key, [79](#)
 Frame Timer key, [79](#)
 Level key, [79](#)
 Slope key, [79](#)
 Trig Holdoff key, [79](#)
trigger out, [32](#)
Trigger Source menu
 Ext Front key, [86](#)
 Ext Rear key, [86](#)
 Free Run key, [86](#)
 Line key, [86](#)
 RF Burst key, [86](#)
 Video key, [86](#)
troubleshooting key, [65](#)

U

Uninstall Now, [41](#)
uninstalling measurement
 personalities, [38](#)
Unlock error annunciator, [36](#), [169](#)
URL
 firmware, [19](#)
 transmitter tester updates, [19](#)

V

Video key, [86](#)
View/Trace key, [87](#)
Visible Align key, [68](#)

W

warm-up times
 functional testing, [135](#)
 test equipment, [135](#)
warranty information, [200](#)
waveform
 making the measurement, [99](#)
 method, [99](#)
 results, [99](#)
Waveform (Time Domain) key, [99](#)
website
 firmware updates, [19](#)
 transmitter tester updates, [19](#)
window
 I/Q waveform, [87](#)
 RF envelope, [87](#)
 spectrum, [87](#)
Window Length key, [95](#)

Z

Zoom, [30](#)